

# Original instruction for use for the gaitway-3D instrumentation

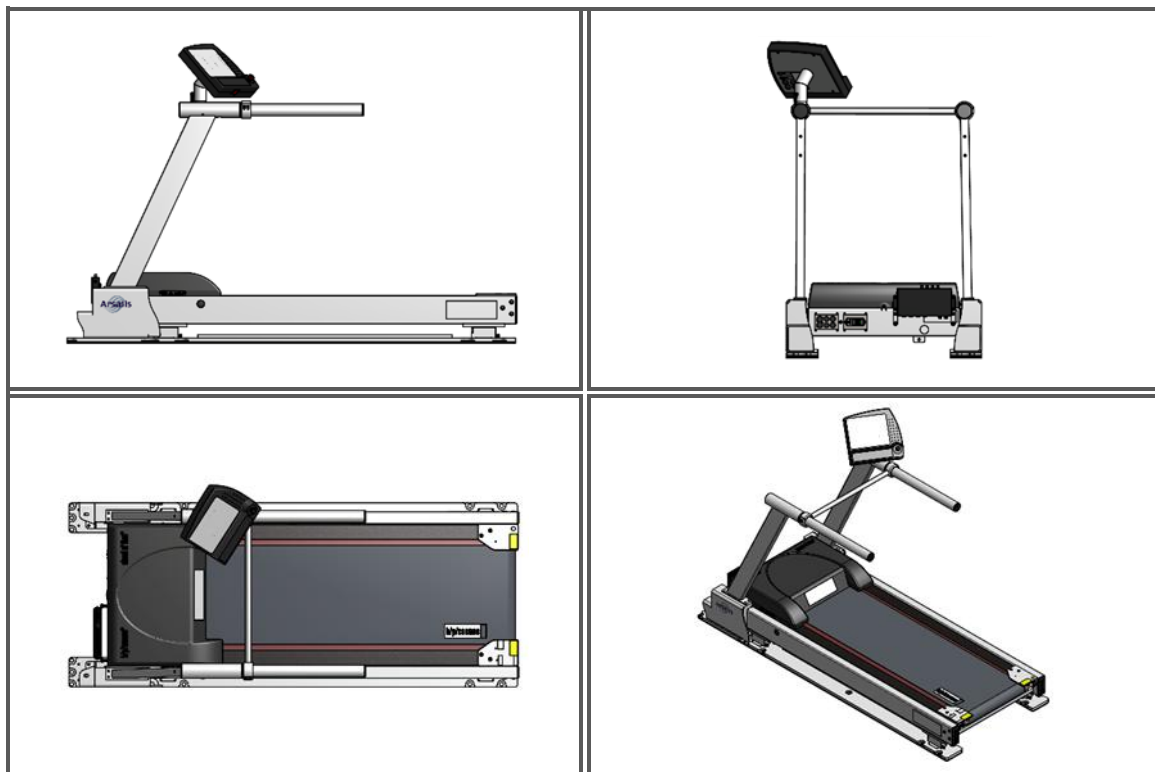

gaitway-3D treadmill manufacturer:

h/p/cosmos: sports & medical gmbh

Am Sportplatz 8

DE 83365 Nussdorf-Traunstein

Germany

phone +49 86 69 86 42 0

fax +49 86 69 86 42 49

[service@hpcosmos.com](mailto:service@hpcosmos.com)

[www.hpcosmos.com](http://www.hpcosmos.com)

Version:

gaitway-3D treadmill firmware: MCU5-v1.08.3

MCU6-v1.8.0521



gaitway-3D Instrumentation manufacturer:

Arsalis SRL

Chemin du Moulin Delay, 6

B-1473 Glabais

Belgium

phone +32 10 474425

fax +32 10 473106

[arsalis@arsalis.com](mailto:arsalis@arsalis.com)

[www.arsalis.com](http://www.arsalis.com)

Version:

gaitway-3D software: 2.1

gaitway-3D force amplifier firmware: 226C, 226D, 226E

Dear customer,

This user manual is only valid for the software / firmware version noted on the first page of this manual and only for the original configuration of the first delivery of the machine. Firmware updates, software updates, changes of the system configuration or retrofitting of additional equipment or accessories can result in invalidity of this manual. In case of alterations of the device or the additional equipment; the latest version of the manual or the corresponding additional information always should be considered.

The user manual for the gaitway-3D system is split in two parts: the present manual covers all service instruction and safety precautions for the **instrumentation** of the gaitway-3D instrumentation; the user instructions and safety precaution for the gaitway-3D **treadmill** are described in the instructions for use of the h/p/cosmos treadmill ergometer. Throughout this manual, the sign below indicates instances where you should consult the gaitway-3D treadmill user manual.

	<p>The present manual only covers the instructions relative to the gaitway-3D instrumentation. More safety notes, warnings, precautions and operational instructions are available in the instructions for use of the h/p/cosmos treadmill ergometer. Please refer to the manual available at the address below:  <a href="https://www.hpcosmos.com/en/contact-support/media-downloads/manuals">https://www.hpcosmos.com/en/contact-support/media-downloads/manuals</a></p>
--	---

The latest version of the present manual is always available in PDF version on the Arsalis website <https://www.arsalis.com/>

	<ul style="list-style-type: none"> <li>▪ It is strictly forbidden to perform any amendments of the technical design, technical specifications, labelling and configurations (except allowed programming as described in this manual) of this machine and the software and accessories connected to this machine.</li> <li>▪ Any amendments, unauthorized, poor or lack of service / maintenance will result in loss of manufacturer's liability and warranty.</li> </ul>
---	--

This user manual as a firm part of the delivery has to be accessible to the user at any time. It has been written with great care. Should you, however, still find any details that do not correspond with your device, please notify us so that we can correct any mistake as soon as possible. This user manual is subject to alterations without prior notice.

We wish you a lot of fun and success while exercising and working with your instrumented treadmill.

Massimo Penta,  
 General Manager  
 Arsalis SRL



## TABLE OF CONTENTS

1.	Model overview.....	1
1.1.	Options and accessories .....	2
2.	Introduction.....	4
2.1.	Description.....	4
2.2.	Device components, including software and accessories.....	4
2.2.1.	gaitway-3D components .....	4
2.2.2.	Gaitway-3D amplifier description.....	5
2.2.3.	Treadmill reference frame and origin.....	9
2.2.4.	gaitway-3D software description.....	11
2.3.	Safety equipment.....	11
3.	Intended use & indications, contraindications, risks & forbidden use .....	12
3.1.	Intended use & indications.....	12
3.2.	System requirements for gaitway-3D software .....	12
3.3.	Contraindications.....	12
3.4.	Risks.....	13
3.5.	Forbidden use.....	13
4.	Safety notes, warnings, precautions.....	14
4.1.	General.....	14
4.2.	Preparation of the patient .....	15
4.3.	Preparation of the gaitway-3D .....	15
4.4.	During patient exercise .....	16
4.5.	Device care.....	17
5.	Operation.....	19
5.1.	General.....	19
5.2.	Connection .....	19
5.2.1.	Connection to treadmill.....	19
5.2.2.	Connection to force amplifier.....	20
5.3.	Software installation .....	20
5.4.	Switch on procedure.....	22
5.5.	.....	22
5.6.	Switch off procedure.....	23
5.7.	Emergency stop, stop buttons, stop functions and safety features.....	23
5.8.	UserTerminal / Control Terminal.....	23
5.9.	gaitway-3D software .....	24
5.9.1.	call gaitway-3D application with arguments.....	24
5.9.2.	Welcome screen and menu.....	24
5.9.3.	Measure screen: Operator, patient and settings.....	28
5.9.4.	Measure screen: Treadmill control .....	33
5.9.5.	Measure screen: Force measure control and display.....	36
5.9.6.	Measure screen: RAW signals .....	37
5.9.7.	Measure screen: DATA signals.....	39
5.9.8.	Measure screen: Ground Reaction Forces.....	41
5.9.9.	Measure screen: Ground Reaction Forces, left & right.....	42
5.9.10.	Measure screen: Center of pressure.....	43
5.9.11.	Measure screen: Center of mass.....	45



5.9.12.	Measure screen: Parameters.....	46
5.9.13.	Measure screen: Left vs Right .....	48
5.9.14.	Measure screen: Feedback .....	49
5.9.15.	Measure screen: SHAKE .....	50
5.9.16.	Measure screen: Virtual split belt.....	52
5.9.17.	Measure screen: Recording.....	54
5.9.18.	Measure screen: Video camera .....	55
5.9.19.	Data stream screen.....	56
5.9.20.	Records list .....	60
5.9.21.	Data viewer .....	62
5.9.22.	Data viewer screen: RAW signals.....	65
5.9.23.	Data viewer screen: DATA signals .....	66
5.9.24.	Data viewer screen: VIDEO .....	68
5.9.25.	Data viewer screen: P-DECK.....	69
5.9.26.	Data viewer screen: STRIDES signals.....	69
5.9.27.	Data viewer screen: AVERAGE signals.....	71
5.9.28.	Data viewer screen: Parameters.....	74
5.9.29.	Data view screen: REPORT .....	76
5.9.30.	Definitions of biomechanical parameters of walking .....	78
5.9.31.	Definitions of biomechanical parameters of running .....	83
5.9.32.	Error messages .....	88
6.	Service.....	91
6.1.	Safety notes, warnings and precautions .....	92
6.1.1.	Room conditions and environmental requirements .....	92
6.1.2.	Transport and installation .....	92
6.1.3.	Storage.....	93
6.2.	Electrical safety features .....	93
6.3.	Connection of external devices via interface .....	94
7.	Maintenance and safety inspections.....	95
7.1.	Measurement accuracy verification .....	95
7.2.	Preventive maintenance .....	96
7.3.	Immediate maintenance .....	96
7.4.	Regular inspections / examinations .....	96
7.5.	Lubrication of the running belt .....	97
7.6.	Control, tightening, adjustment and centering of the running belt.....	97
7.7.	Cleansing.....	97
7.8.	Incline handling.....	98
7.9.	Portable option handling .....	99
8.	Troubleshooting.....	100
9.	Technical data .....	102
9.1.	Economic life time .....	104
10.	Disposal .....	104
11.	Certificates .....	104
12.	Symbols .....	104
13.	Contact.....	106
14.	Appendices .....	107
14.1.	Instruction protocol, signatures .....	107



---

15.	Scientific references .....	108
16.	DOCUMENTS .....	a
16.1.	Applicable documents .....	a
16.2.	Reference documents .....	a

## 1. Model overview

This user manual is applicable to the instrumentation of the gaitway-3D 150/50 instrumented treadmill (Figure 1), gaitway-3D 170/65 instrumented treadmill (Figure 2) and gaitway-3D 190/65 (Figure 3) instrumented treadmill.



Figure 1. gaitway-3D 150/50 overview.

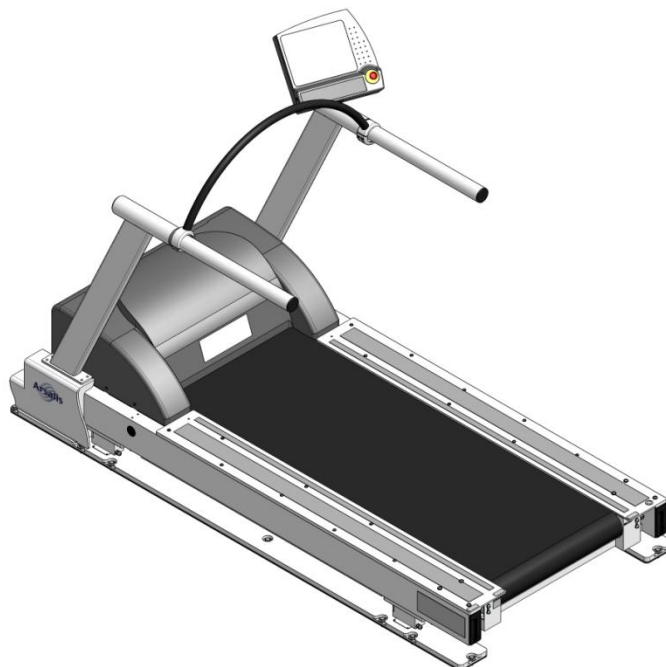

Figure 2. gaitway-3D 170/65 overview.

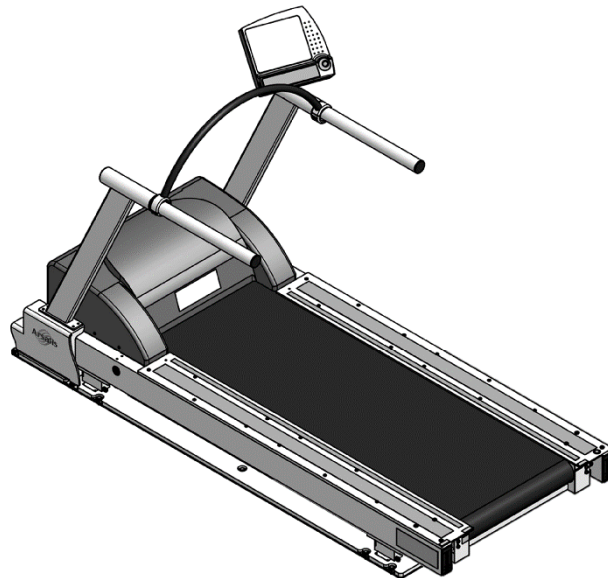



Figure 3. gaitway-3D 190/65 overview.

	<p>More information on the gaitway-3D treadmill model overview is available in the instructions for use of the h/p/cosmos treadmill ergometer. Please refer to the manual available at the address below: <a href="https://www.hpcosmos.com/en/contact-support/media-downloads/manuals">https://www.hpcosmos.com/en/contact-support/media-downloads/manuals</a></p>
---	---

### 1.1. Options and accessories

The options and accessories available for gaitway-3D are listed in Table 1.

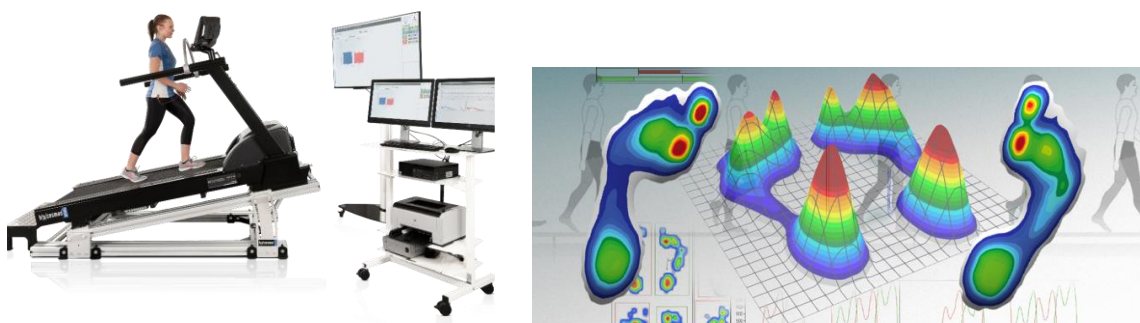

Figure 4. Example gaitway-3D options.

**Table 1. gaitway-3D options and accessories.**

Elevation 0% to +20% for gaitway® 3D 150/50	cos102999_150-50elev
Elevation 0% to +20% for gaitway® 3D 170/65	cos102999_XXX-65elevva02
Elevation 0% to +20% for gaitway® 3D 190/65	cos102999_XXX-65elevva01
Special speed* 0 - 30 km/h 170/65 (MCU6)	cos103975
Portable baseplate gaitway 3d with wheels for gaitway 150/50	cos103752va01
Portable baseplate gaitway 3d with wheels for gaitway 170/65	cos103752va02
Portable baseplate gaitway 3d with wheels for gaitway 190/65	cos103752va03
Wheels for gaitway incline module for gaitway 150 - 190	cos103971
Noraxon Package 3D Force and Pressure Treadmill	cos102999ip_set
zebris® FDM pressure measuring platform 2i for running deck 150/50	cos103335-01va02
zebris® FDM pressure measuring platform 3i for running deck 150/50	cos103566va01
zebris® FDM pressure measuring platform 2i for running deck 170/65	cos102292
zebris® FDM pressure measuring platform 3i for running deck 170/65	cos102293va02
zebris® FDM pressure measuring platform 2i for running deck 190/65	cos102294
zebris® FDM pressure measuring platform 3i for running deck 190/65	cos101629
zebris® modular extension with 120 Hz for running deck 150/50	cos101733
zebris® modular extension with 180 Hz for running deck 170/65	cos101734
zebris® modular extension with 100 Hz for running deck 190/65	cos103308
USB 3.0 glass fiber cable A/A 20 m	cos103312
h/p/cosmos satellite PC med	cos14970-03
"Science port" speed output TTL	cos101277
Connection cable RS232 5 m	cos00097010034
Connection cable RS232 10 m	cos00097010035
USB to RS232 converter	cos12769-01
Potential equalization cable 5 m (with 2 POAG-plugs)	cos10223-01
analog interface cable for gaitway 3D	cos102999d
zebris FDM Sync-In Cable Noraxon	cos102999u
LCD monitor TV 50" (with a small monitor stand for table)	cos102397
Monitor stand mobile for LCD TV 32-60"	cos101624
Digital data streaming interface module	cos102999ds
External GRF-decomposition module	cos102999grf
Vicon Nexus plugin module	cos102999vic
Qualisys L-frame small adapter	cos102999qual_L
Perturbation-option for gaitway 3D	cos102999pert_MCU6

## 2. Introduction

The following section describes the instrumentation of the gaitway-3D.



More information on the gaitway-3D treadmill model overview is available in the instructions for use of the h/p/cosmos treadmill ergometer. Please refer to the manual available at the address below:  
<https://www.hpcosmos.com/en/contact-support/media-downloads/manuals>

### 2.1. Description

The gaitway-3D is an instrumented treadmill based on an h/p/cosmos treadmill, equipped with three-dimensional ground reaction force measurement load cells. The system measures the ground reaction forces in all directions and thereby collects a large amount of force and time-based gait parameters. The ground reaction force and the position of the center of pressure can be displayed with the gaitway-3D<sup>®</sup> software.

### 2.2. Device components, including software and accessories

#### 2.2.1. gaitway-3D components

The gaitway-3D instrumentation is composed of three components:

- 1) The left and right treadmill supports that each includes two force transducers and a handrail-support fixed on a foot-plate anchored to the floor (Figure 5).
- 2) The force amplifier is fixed in front of the treadmill.
- 3) The gaitway-3D software runs on a user-provided personal computer running the Windows<sup>®</sup> operating system.

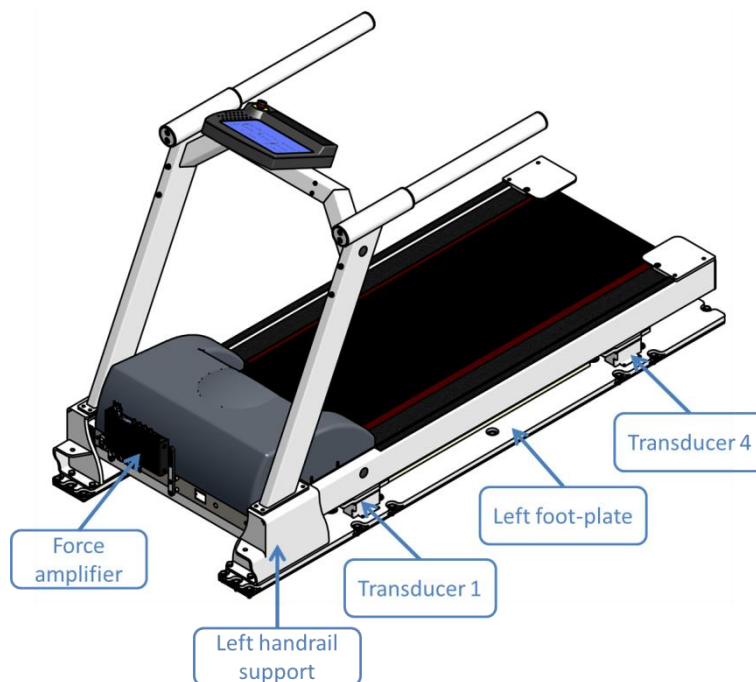

Figure 5. gaitway-3D instrumentation components.

## 2.2.2. Gateway-3D amplifier description

The force amplifier is composed of a powder coated stainless steel enclosure with connectors on the top and bottom panels. The force amplifier is mounted on two brackets located in front of the treadmill motor compartment (see Figure 5). Several versions of the gateway-3D amplifier are supported (versions C, D and E). The amplifier interface connectors are described in next sections. Standard PVC or PUR jacket cables are used for interconnection between the amplifier and parts of the gateway-3D instrumentation.

### 2.2.2.1. Amplifier bottom panel

The bottom panel includes all connectors used by internal treadmill components; i.e. the connectors for the four transducers, the treadmill speed sensor and the power supply input to the instrumentation, see Figure 6.

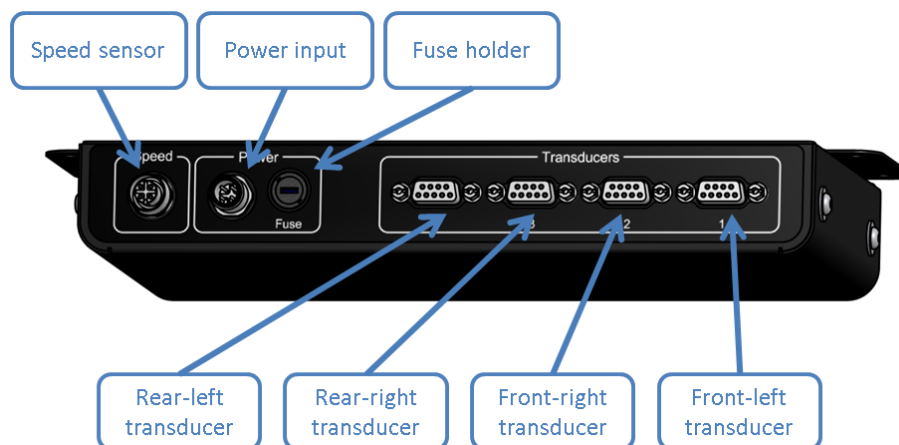

Figure 6. gateway-3D amplifier bottom panel (versions C, D, E).



- The connectors on the bottom panel shall not be disconnected from the amplifier except for service purposes.

### 2.2.2.2. Amplifier top panel

The top panel is presented in Figure 7 and includes all user interface connectors:

- the Ethernet connector;
- the activity LEDs;
- four BNC digital connectors;
- the analog force output connector (version C & D) or analog forces and treadmill speed output connector (version E).

### 2.2.2.3. Ethernet connector

The Ethernet connector is used to connect the amplifier to a LAN network with the operator computer to control the gateway-3D instrumented treadmill with gateway-3D software.

The amplifier shall be connected to a LAN network with the supplied Ethernet cable or with a CAT5E or better Ethernet cable.

**2.2.2.4. Status LED**

The status LED (red) shows the status of the gaitway-3D instrumentation according to the different states described in Table 2.

**Table 2. Status LED state description.**

Status LED state	Description
LED is OFF	The gaitway-3D instrumentation is not powered.
LED blink at 1Hz with a duty cycle of 1/8	The gaitway-3D instrumentation is operational and no error is logged.
the LED blink at 1 Hz and makes a double flash	The gaitway-3D instrumentation is acquiring data.
LED is always on	The gaitway-3D instrumentation is waiting for a trigger.
LED blink fast	The gaitway-3D instrumentation is operational and at least one error is logged.

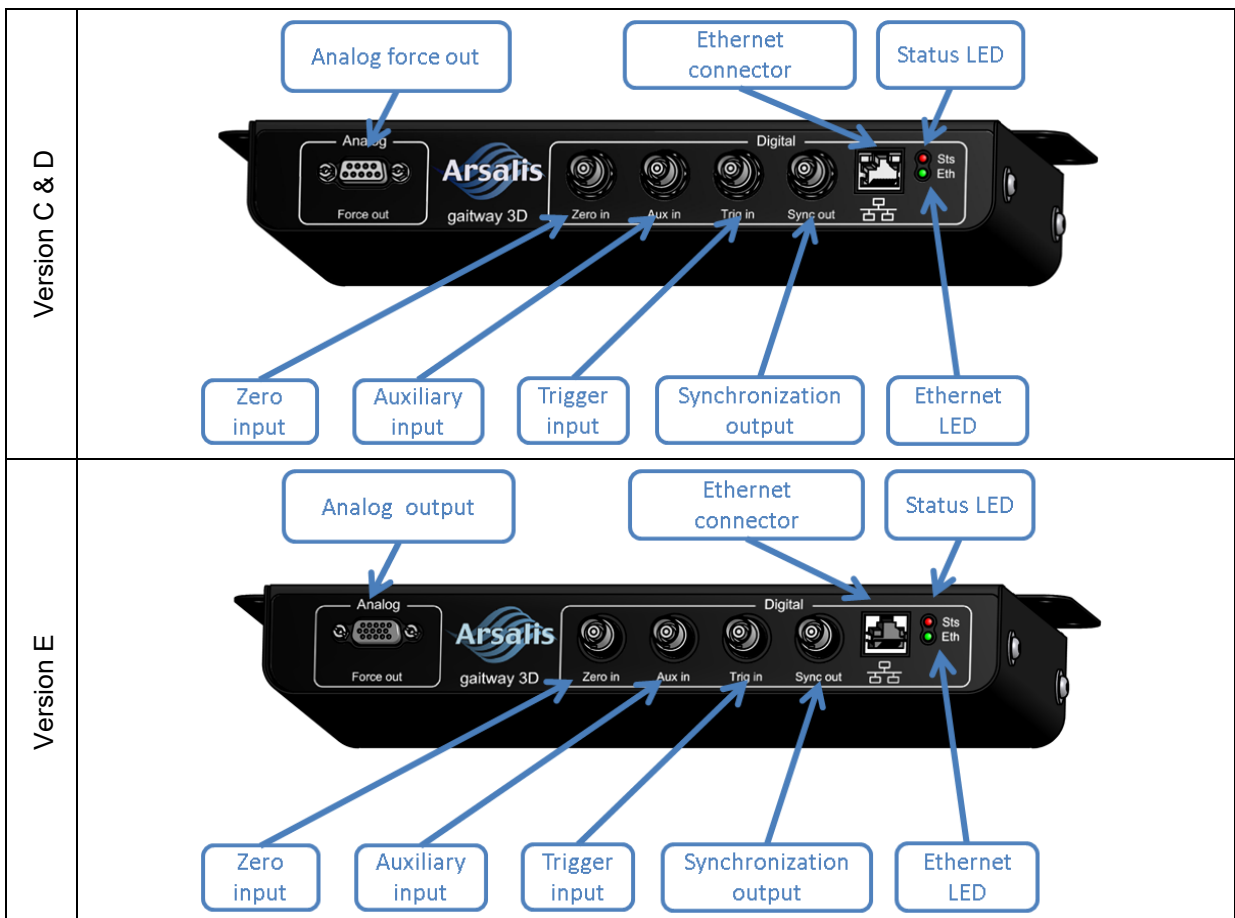

**Figure 7. gateway-3D amplifier top panel.**

### 2.2.2.5. Ethernet LED

The Ethernet activity LED (green) shows the status of the gaitway-3D instrumentation Ethernet connection according to the different states described in Table 3.

**Table 3. Ethernet LED state description.**

Status LED state	Description
LED is OFF	No Ethernet Link.
LED is ON	Ethernet Link is established.
LED is flashing	Activity on the Ethernet port.

### 2.2.2.6. Digital connectors

The digital connectors of the gaitway-3D amplifier are used for one of the following functions:

- to provide trigger start or stop signals;
- to clock external devices in synchrony with the data recording of the gaitway-3D;
- to reset the baseline analog output signals.

All digital inputs and outputs are isolated and rated for 5V digital operation with standard TTL/CMOS logic levels. There are three digital inputs and one programmable output.

The "Trig in" and "Aux in" digital inputs are used as start or stop trigger or as passive input to record digital signals in synchrony with the ground reaction forces. The behavior of these inputs (i.e. polarity, start or stop trigger) are under the control of gaitway-3D software.

The "Zero in" is a digital input that triggers a reset of the output baseline of the eight analog force signals when it is pulled low.



- The "Zero in" function should be used when the patient is not on gaitway-3D treadmill and when no object is touching the treadmill.
- The "Zero in" function is ignored during acquisition of the ground reaction force signals.

The behavior of the "Sync out" digital output (i.e. polarity, frequency) is also under control of the gaitway-3D software. The digital output is rated for 10 mA

### 2.2.2.7. Analog force output

The Analog Force output connector is used to provide an analog copy of the eight force signals measured by the force transducers (version C, D and E) and of the treadmill speed (version E only). The voltage output for each signal is ground referenced, within a range of 0 to 10 V and is rated 10 mA for version C & D1 and 1 mA for version D2 and E and has an impedance of 100 Ohm. The internal analog ground of the amplifier is separated from the external ground (GNDIO) with a 100 Ohm resistor. The connector pin-out is presented in Table 4 and in Figure 8.

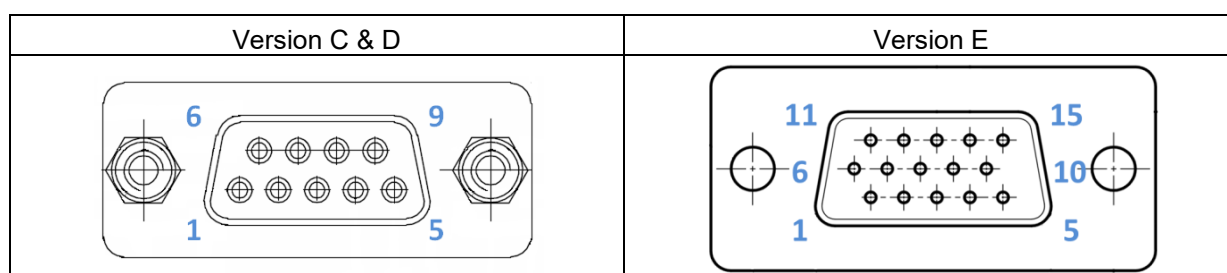

Figure 8. Analog force out connector front panel pin-out view

Table 4. Analog force out connector pin-out (version C, D and E).

Pin number		Signal	Type	Description
v. C&D	v. E			
1	1	LPF_EX34_OUT	Filtered analog signal	Sum of Rear Left and Rear Right force sensors in the X direction
2	2	LPF_EX12_OUT	Filtered analog signal	Sum of Front Left and Front Right force sensors in the X direction
3	3	LPF_EY23_OUT	Filtered analog signal	Sum of Front Right and Rear Right force sensors in the Y direction
4	4	LPF_EY14_OUT	Filtered analog signal	Sum of Front Left and Rear Left force sensors in the Y direction
5	5	LPF_EZ4_OUT	Filtered analog signal	Force in Z direction on Rear Left force sensor
6	6	LPF_EZ3_OUT	Filtered analog signal	Force in Z direction on Rear Right force sensor
7	7	LPF_EZ2_OUT	Filtered analog signal	Force in Z direction on Front Right force sensor
8	8	LPF_EZ1_OUT	Filtered analog signal	Force in Z direction on Front Left force sensor
NA	10	SPEED_OUT	Filtered analog signal	Analog treadmill speed
9	15	GNDIO	External ground	External ground for signal reference
Shield	Shield	Chassis	PE	Connected to chassis of amplifier

### 2.2.3. Treadmill reference frame and origin

The sensors measure the three-dimensional forces applied to the treadmill. These forces are expressed by the amplifier in the reference frame presented in Figure 9.

gateway-3D 150/50 with mercury or stratos treadmill, SN: cos30000va

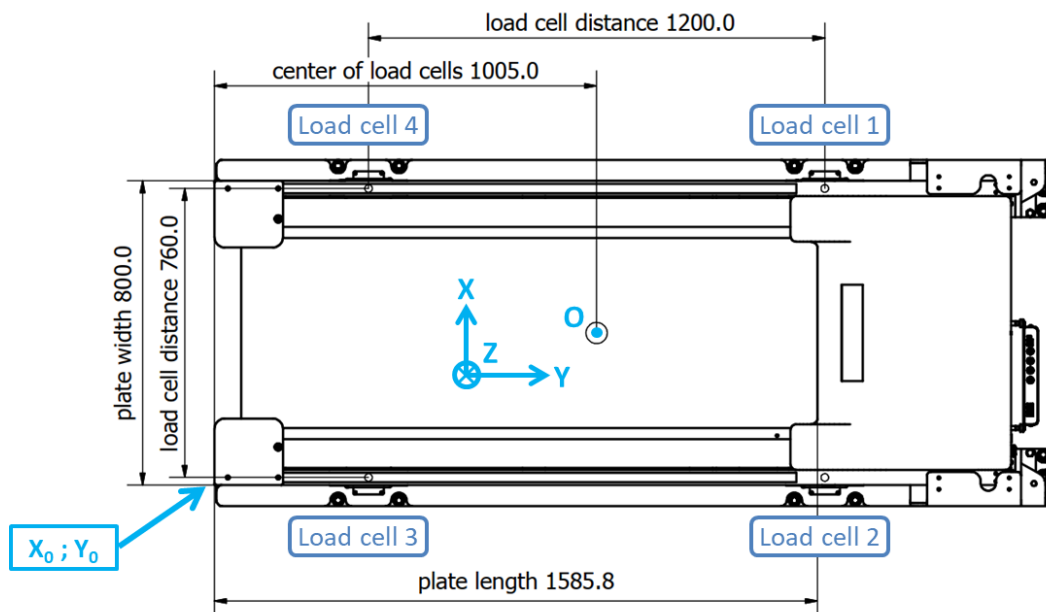

gateway-3D 150/50 with pluto treadmill, SN: cos30000-02

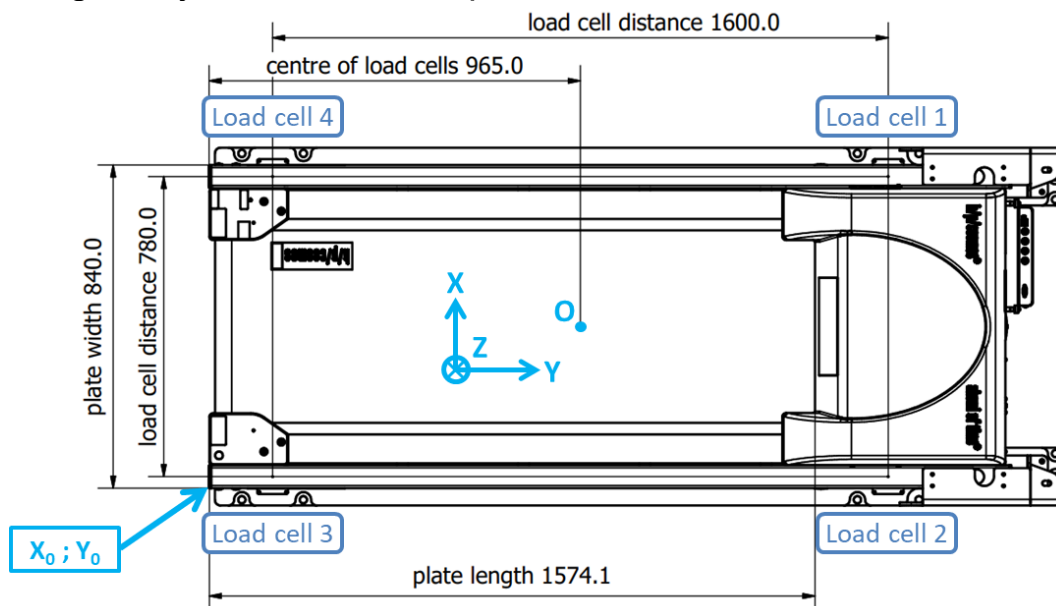

gaitway-3D 170/65 with quasar or stellar treadmill, SN: cos30003

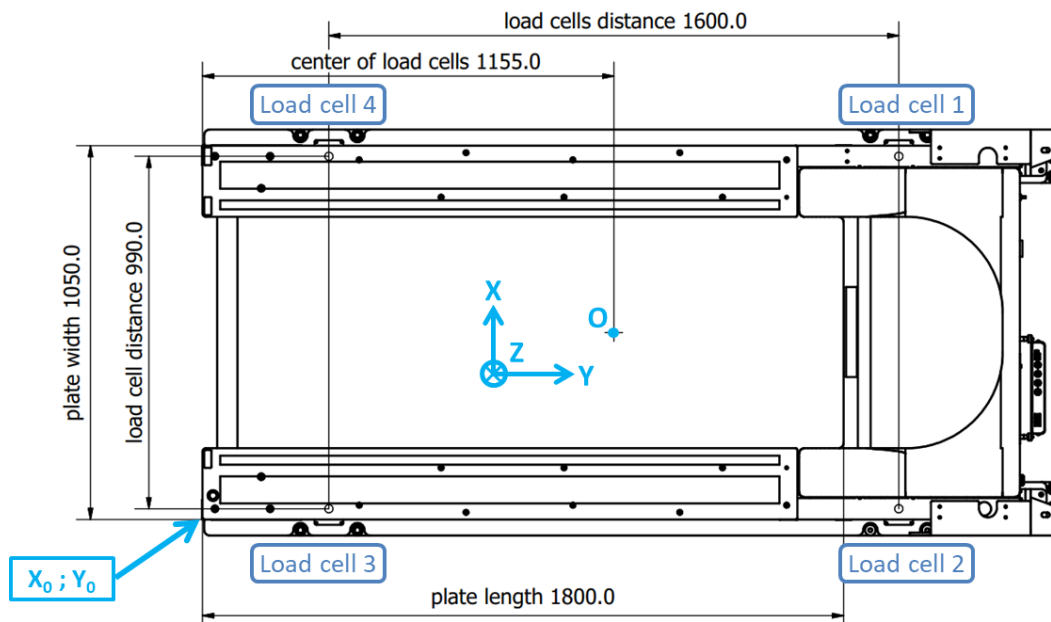

gaitway-3D 190/65 with pulsar treadmill, SN: cos30004

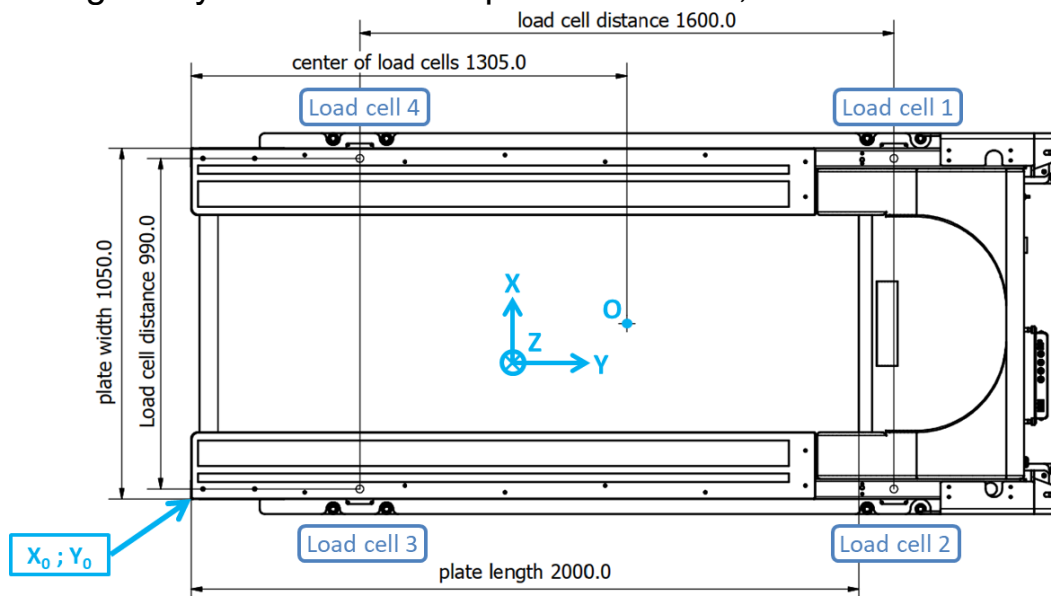

Figure 9. Treadmill top view and reference frame.

A transducer is mounted at each corner of the treadmill (transducer 1 to 4). The four top views in Figure 9 show the location of the origin, the rear right corner of the treadmill,  $(X_0; Y_0)$  used in gaitway-3D software relative to the geometrical center of the rectangle defined by the four transducers (O in Figure 9). All dimensions are expressed in millimeters and the three orthogonal components of the applied force (not the ground reaction force) are reported as follows:

- vertical component along the Z-axis, positive downwards;
- fore-aft components along the Y-axis, positive forwards;
- medio-lateral component along the X-axis, positive leftwards.

### 2.2.4. gaitway-3D software description

The gaitway-3D software is for remote control of the gaitway-3D treadmill and force amplifier, measuring the applied forces on the gaitway-3D treadmill walking/running surface and calculating the biomechanical parameters in walking or running gaits. The gaitway-3D software is designed for sports and fitness applications. The gaitway-3D software is neither intended for medical diagnosis nor medical evaluation and it does not give recommendations for treatment.

### 2.3. Safety equipment

The gaitway-3D instrumentation does not include safety equipment but it is important to have the knowledge of the safety equipment of the gaitway-3D treadmill to use it.



More information on the gaitway-3D treadmill safety equipment is available in the instructions for use of the h/p/cosmos treadmill ergometer. Please refer to the manual available at the address below:  
<https://www.hpcosmos.com/en/contact-support/media-downloads/manuals>

### 3. Intended use & indications, contraindications, risks & forbidden use

The following sections describe the intended use & indications, contraindications, risks and forbidden uses of the gaitway-3D instrumentation. The gaitway-3D instrumented treadmill also includes an h/p/cosmos treadmill and includes all functions of this treadmill.

	<p>More information on the gaitway-3D treadmill intended use &amp; indications, contraindications, risks and forbidden uses is available in the instructions for use of the h/p/cosmos treadmill ergometer. Please refer to the manual available at the address below: <a href="https://www.hpcosmos.com/en/contact-support/media-downloads/manuals">https://www.hpcosmos.com/en/contact-support/media-downloads/manuals</a></p>
---	--

#### 3.1. Intended use & indications

The gaitway-3D instrumentation is intended to measure, record and visualize the ground reaction forces in each direction and the position of center of pressure of the force applied on the treadmill. The person on the treadmill is called the patient and the person that uses the gaitway-3D software is called the operator. The gaitway-3D instrumentation has two main intended uses. First, a patient exercises on the gaitway-3D while the operator controls the treadmill and monitors or records the ground reaction forces exerted by the patient. Second, the operator, visualizes recorded data for biomechanical analysis and reporting, without neither the required presence of the patient nor the required connection to the gaitway-3D hardware.

#### 3.2. System requirements for gaitway-3D software

The operator computer running the gaitway-3D software must have at least the following specifications:

- Personal or laptop computer with microprocessor clocked at 2 GHz or higher.
- Installed operating system Windows 11 (64-bit).
- Mouse with scroll-wheel and keyboard.
- Minimum 16 GB of RAM.
- Minimum 50 GB of free hard disk space.
- Minimum screen resolution of 1280 x 768 pixels.
- 1x RS-232 interface port or 1x USB port
- 1x Ethernet port 10/100 Mbps or Gigabit.

#### 3.3. Contraindications

- The recording of meaningful data can only be achieved by trained operators.
- The correct interpretation of ground reaction forces and center of pressure data can only be achieved by experts with knowledge of the biomechanics of locomotion.

	<p>More information on the contraindications for a patient to exercise on the gaitway-3D treadmill is available in the instructions for use of the h/p/cosmos treadmill ergometer. Please refer to the manual available at the address below:  <a href="https://www.hpcosmos.com/en/contact-support/media-downloads/manuals">https://www.hpcosmos.com/en/contact-support/media-downloads/manuals</a></p>
---	--

### 3.4. Risks

The gaitway-3D instrumentation does not generate any specific risk to the patient nor operator. Nevertheless, it is important that the patient and operator have the knowledge of the risks associated with exercise on a treadmill ergometer.

	<p>More information on the gaitway-3D treadmill risks is available in the instructions for use of the h/p/cosmos treadmill ergometer. Please refer to the manual available at the address below:  <a href="https://www.hpcosmos.com/en/contact-support/media-downloads/manuals">https://www.hpcosmos.com/en/contact-support/media-downloads/manuals</a></p>
---	---

### 3.5. Forbidden use

- All prohibitions in the chapter entitled "Safety precautions, safety regulations, prohibition and warnings".
- Do not modify the gaitway-3D instrumentation and do not connect any other equipment which is not explicitly declared as compatible by the manufacturer.
- The gaitway-3D instrumentation must not be used without carefully trained specialist staff and without the staff having been instructed on the safety regulations.
- Any other use than the explicitly mentioned intended use is forbidden.
- In the event of any detected and/or assumed malfunctions and/or defects or unreadable safety warning labels, the device has to be taken out of operation, clearly marked as such and disabled. The supplier and authorized service personnel have to be informed in writing.
- The device must not be used if one or more of the listed contraindications prevail (see chapter entitled "Contraindications").

	<ul style="list-style-type: none"> <li>▪ The gaitway-3D software stores personal data that need to be protected from unwanted access. If unauthorized persons are believed to have access to the gaitway-3D software or if there are other reasons to lock the software, it has to be blocked by setting a safe password.</li> <li>▪ The gaitway-3D instrumentation cannot be used for a medical application.</li> </ul>
---	--

	<p>More information on the gaitway-3D treadmill forbidden use is available in the instructions for use of the h/p/cosmos treadmill ergometer. Please refer to the manual available at the address below:  <a href="https://www.hpcosmos.com/en/contact-support/media-downloads/manuals">https://www.hpcosmos.com/en/contact-support/media-downloads/manuals</a></p>
---	---

## 4. Safety notes, warnings, precautions

### 4.1. General



	<ul style="list-style-type: none"> <li>▪ Important notes, warnings and precautions are marked with this sign. It also reminds you of concerns which have to be considered for measurements and connection with other devices.</li> </ul>
---	--

- These operating instructions are part of the device and must always be accessible for every user.
- Exact observance of the operating instructions is required for appropriate operation of the gaitway-3D device.
- Before using the gaitway-3D instrumentation, read carefully the operating instructions, especially the safety notes, warnings and precautions.
- The safety notes, warnings and precautions have to be pointed out to every patient and operator and displayed within sight of the device.
- The gaitway-3D software must only be used after careful instruction by authorized field service personnel.
- All regulations and prohibitions are to be followed.
- Safety, reliability, function and accuracy can only be achieved if the device is used in accordance with the operating instructions, including the use of the described consumables, sensors and detectors, installation, commissioning, instruction, extension, alteration, recommended preventive maintenance, safety checks and repair are performed by trained and authorized staff.
- The manufacturer has no liability for any injury to persons or damage to property.

	<ul style="list-style-type: none"> <li>▪ Disregard of intended use, safety notes, warnings and precautions, unauthorized or lack of maintenance and / or regular safety checks may lead to injuries or even death and / or can damage the device and will result in loss of any liability and warranty.</li> </ul>
---	--

	<p>More information on the gaitway-3D treadmill general safety notes, warnings and precautions is available in the instructions for use of the h/p/cosmos treadmill ergometer. Please refer to the manual available at the address below:</p> <p><a href="https://www.hpcosmos.com/en/contact-support/media-downloads/manuals">https://www.hpcosmos.com/en/contact-support/media-downloads/manuals</a></p>
---	--

## 4.2. Preparation of the patient

	<ul style="list-style-type: none"> <li>▪ When using the safety arch with chest belt system, ensure that no load is applied by the chest belt on the patient that can alter the ground reaction forces to the patient.</li> <li>▪ The gaitway-3D records the resultant of all loads applied to the treadmill and therefore, only the loads applied by the patient should be measured for proper biomechanical interpretation.</li> </ul>
	<p>More information on the preparation of the patient for the gaitway-3D treadmill is available in the instructions for use of the h/p/cosmos treadmill ergometer. Please refer to the manual available at the address below:</p> <p><a href="https://www.hpcosmos.com/en/contact-support/media-downloads/manuals">https://www.hpcosmos.com/en/contact-support/media-downloads/manuals</a></p>

## 4.3. Preparation of the gaitway-3D

	<ul style="list-style-type: none"> <li>▪ Ensure that no object can touch the gaitway-3D treadmill during exercise; this will alter the measured ground reaction forces to the patient.</li> <li>▪ The system records the resultant of all loads applied and therefore, only the loads applied by the patient should be measured for proper biomechanical interpretation.</li> </ul>
---	---

- The operator computer shall be installed in a position where the operator sees the patient's face to facilitate communication with the patient and monitoring of the patient.
- Switch on the gaitway-3D at least 15 minutes before recording the ground reaction forces.
- The signal recording could be interfered/perturbed in case of electromagnetic noise in the environment of the device. In order to confirm the absence of electromagnetic noise perform the following "on site EMC noise test". Start viewing the measured forces in the gaitway-3D software during at least 30 seconds before the exercise. Enter the "Measure screen" without applying any load to the device and confirm in the GRF display that (1) the baseline load remains at 0N on Fz, Fy and Fx, (2) that no sudden change in force is measured on Fz, Fy and Fx and (3) that no high speed noise is measured on Fz, Fy and Fx.



- If this procedure shows no deviations or fluctuations of the baseline, then the environment is considered to be free of relevant interference and electromagnetic noise.
- In case the “on site EMC noise test” shows any deviations or fluctuations then do not perform measurements, since heavy interference will result in wrong force measurements.

- Ensure that all cables (power connection, Ethernet, interface, potential equalization, etc.) and accessories are installed properly and safely and that nobody can stumble or fall over the cables and/or accessories.
- Only connect accessories, software and host equipment if they are approved as compatible by the manufacturer. Non-compliance to this clause can lead to serious injury or death and loss of manufacturer warranty and liability.



More information on the preparation of the gaitway-3D treadmill is available in the instructions for use of the h/p/cosmos treadmill ergometer. Please refer to the manual available at the address below:  
<https://www.hpcosmos.com/en/contact-support/media-downloads/manuals>

#### 4.4. During patient exercise

- The first steps for patients accustomed to treadmill walking or the first minutes for patients discovering treadmill walking are not representative of their natural walking. Do not use measurements from this habituation period.
- The measurements done when the patient touches the handrails are not representative of walking without aid. Do not use measurements done when the patient touches the handrails on any other part than the locomotion surface.
- Any eventual person or material that needs to be present close to the patient during exercise cannot touch the treadmill to avoid perturbation of the measurements.
- The signal recordings could be perturbed in case of electrostatic discharge on the treadmill. Discharge the patient on an earthed metal piece or the treadmill structure before the measurement. Other persons or objects should not touch the treadmill structure during operations.
- The signal recording could be interfered/perturbed in case of electromagnetic noise in the environment of the device. In case of a sudden change or a high speed noise on the force recordings, stop and restart the data viewing in the gaitway-3D software (see section 5.9.5) and discard any recording.

	<ul style="list-style-type: none"> <li>▪ Do not use electromagnetic emitters (mobile phone, Wi-Fi ...) near the device during operations.</li> <li>▪ The correct interpretation of ground reaction forces and center of pressure data can only be achieved by experts with knowledge of the biomechanics of locomotion.</li> <li>▪ Sudden changes in data and/or high speed changes in data may result from electromagnetic sensitivity of the device or from electrostatic discharge to the device, rather than from physiological signals. Ensure that data are not misinterpreted by repeating and confirming any suspicious recording.</li> </ul>
---	---

- Due to the mass of the treadmill, the measurements are sensitive to the vibrations of the floor. Do not use data measured when the floor is subject to vibrations (e.g. other person are running in the room, displacement of heavy mass, use of other vibrating equipment in the building, subway passage nearby building).
- **WARNING!** Heart rate monitoring systems may be inaccurate.

	<ul style="list-style-type: none"> <li>▪ Do not disturb the patient equilibrium by showing him measurements or any other information during exercise except if the display is placed straight in front of the patient.</li> </ul>
---	---



	<p>More information on the safety notes, warnings, precautions during patient exercise on the gaitway-3D treadmill is available in the instructions for use of the h/p/cosmos treadmill ergometer. Please refer to the manual available at the address below:</p> <p><a href="https://www.hpcosmos.com/en/contact-support/media-downloads/manuals">https://www.hpcosmos.com/en/contact-support/media-downloads/manuals</a></p>
---	--

#### 4.5. Device care

- Connector caps have to be installed on unused connectors of the instrumentation amplifier top panel.
- Damaged socket connections and wires are to be replaced immediately by trained and authorized personnel.
- Fluid entering into the device is to be removed immediately by the authorized customer service and a safety check is to be performed.
- Recording, controlling and / or program sequence can be interrupted and there may be stops or other complications if the software requirements are not fulfilled (see section entitled Software requirements).
- During the control of gaitway-3D by the gaitway-3D software no other connection to the network (e.g. LAN, Internet) are allowed. This includes any automatic update, printing, downloading or any incoming or outgoing communication. These options shall be turned OFF during device control by the gaitway-3D software.
- The gaitway-3D software may not be operated from a desktop remote control service (e.g. Remote connection), otherwise the recording,

controlling and / or program sequence can be interrupted, and stops or other complications may occur.

- The connection of any external device to the operator computer (e.g. CD insertion, USB key, external hard disk) is not allowed during device control by the gaitway-3D software, otherwise the recording, controlling and / or program sequence can be interrupted, and stops or other complications may occur.
- With external USB keyboard / mouse, and long press or repeatedly press of the Shift key during device control by the gaitway-3D software, the recording, controlling and / or program sequence can be interrupted, and stops or other complications may occur.
- During long periods of lack of keyboard and mouse activity on the operator computer, the recording, controlling and / or program sequence can be interrupted, and stops or other complications may occur. Remedy: Turn OFF the power saving features of the operator computer. Workaround: disable the screen saver of the operator computer.
- The maintenance and safety inspections have to be followed to ensure a safe operation and accurate measurements of gaitway-3D. Any failure to respect the maintenance program described in section 7 may lead to injuries or death and/or can damage the device. Furthermore it will result in loss of any liability and warranty

	<ul style="list-style-type: none"> <li>▪ In case of any detected and/or assumed malfunctions and/or defects or unreadable safety labels, the device must be discontinued immediately. The device must be marked accordingly and its operation discontinued (e.g. by pulling the power plug and affixing a warning/defect label on the power plug). The supplier and authorized service personnel are to be informed in writing immediately.</li> <li>▪ Shock of hard parts (e.g. exercise weights, metallic objects, tools) or heavy masses on the treadmill can damage the load sensors.</li> <li>▪ Do not apply a load on the treadmill exceeding the maximum load of the sensor of 12000N in any direction.</li> <li>▪ No other PC software, program or application shall be running on the operator computer while controlling the device with the gaitway 3D software, due to possible conflicts or interference with the software.</li> <li>▪ The manufacturer has no liability for any malfunction or misconfiguration of the operator computer or any malfunction of the operating system of the operator computer.</li> </ul>
	<p>More information on the gaitway-3D treadmill machine care is available in the instructions for use of the h/p/cosmos treadmill ergometer. Please refer to the manual available at the address below:  <a href="https://www.hpcosmos.com/en/contact-support/media-downloads/manuals">https://www.hpcosmos.com/en/contact-support/media-downloads/manuals</a></p>

## 5. Operation

### 5.1. General

Before using the gaitway-3D instrumented treadmill you should consult and follow the instructions for use of the gaitway-3D treadmill.

	<p>More information on the instruction of use of the gaitway-3D treadmill is available in the instructions for use of the h/p/cosmos treadmill ergometer. Please refer to the manual available at the address below:  <a href="https://www.hpcosmos.com/en/contact-support/media-downloads/manuals">https://www.hpcosmos.com/en/contact-support/media-downloads/manuals</a></p>
---	---

The usage of the gaitway-3D requires an operator to control and monitor the treadmill and force measurements and a patient to walk, run or stand on the treadmill.

	<p>More information on patient and operator activities for the gaitway-3D treadmill is available in the instructions for use of the h/p/cosmos treadmill ergometer. Please refer to the manual available at the address below:  <a href="https://www.hpcosmos.com/en/contact-support/media-downloads/manuals">https://www.hpcosmos.com/en/contact-support/media-downloads/manuals</a></p>
--	---

### 5.2. Connection

#### 5.2.1. Connection to treadmill

The connection between the operator computer and the gaitway-3D treadmill must be made with a 9-pole Sub-D interface cable with crossed transmission-receive-wires according to Figure 10. It is recommended to select the port COM1 on the gaitway-3D treadmill to connect to gaitway-3D software. It is also recommended to set the baud rate to 115200 baud in the treadmill COM port options (MCU5). Follow the h/p/cosmos instructions for use to change the COM port baud rate.

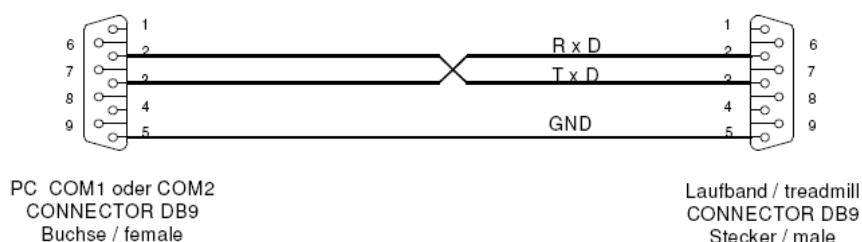



Figure 10. Interface cable from operator computer to gaitway-3D treadmill.

	<p>More information on the serial connection and COM port settings for the gaitway-3D treadmill is available in the instructions for use of the h/p/cosmos treadmill ergometer. Please refer to the manual available at the address below:  <a href="https://www.hpcosmos.com/en/contact-support/media-downloads/manuals">https://www.hpcosmos.com/en/contact-support/media-downloads/manuals</a></p>
---	---



If the operator computer is not equipped with a RS-232 interface, you can use also an USB/RS-232 converter which can be connected to a USB port of the operator computer. Please note that not all USB/RS-232 converters are working properly. It is strongly recommended to order a tested converter from h/p/cosmos.

### 5.2.2. Connection to force amplifier



The connection between the operator computer and the gateway-3D force amplifier must be made with the Ethernet cable delivered with your device through a router. The configuration of the Network is required for proper communication with the force amplifier. Follow the instructions in the section gateway-3D software installation (section 5.3) below to configure the network on the operator computer.

### 5.3. Software installation

For installation of the gateway-3D software and network configuration, follow the step by step installation process below:

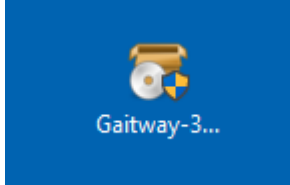
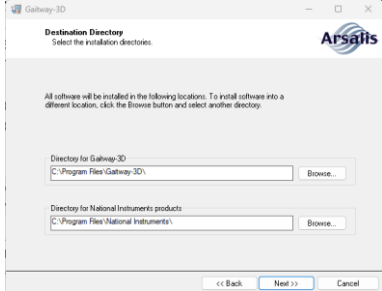
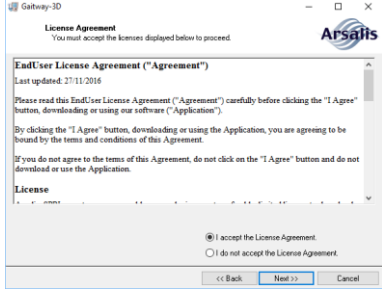
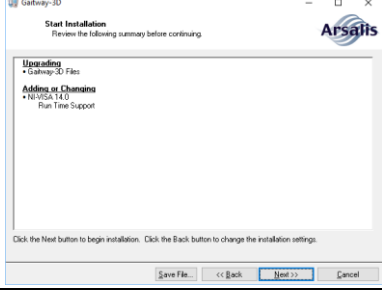
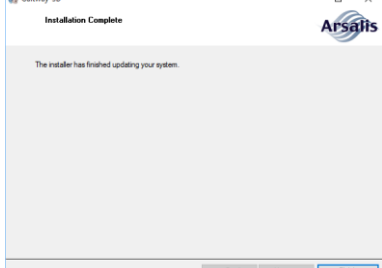
Step	Description	Comment / Illustration
1.	<p><b>Login</b> Switch on the computer and login with administrator rights.</p>	<p>The operator computer should run the Windows operating system and meet the minimum requirements listed in section 3.2.</p>
2.	<p><b>Ethernet connection configuration</b></p> <p><u>Scenario 1</u> Direct connection: Connect an Ethernet cable between the operator computer and one Ethernet Adapter. Set the TCP/IPv4 parameters on the operator computer to a fix IP address within the range 192.168.0.2 to 192.168.0.100.</p> <p><u>Scenario 2:</u> Connection via a router. Connect an Ethernet cable between the operator computer and one router LAN port. Enable the DHCP server of the router. Set the TCP/IPv4 parameters on the operator computer to obtain an IP address automatically.</p>	<p><u>Scenario 1</u> PC (TCP/IPv4) configuration example: - IP address = 192.168.0.100 - subnet mask = 255.255.255.0 - Default gateway: 192.168.0.1</p> <p>The gateway-3D amplifier will use: IP address: 192.168.0.101</p> <p><u>Scenario 2</u> Router configuration example: - Router IP address = 192.168.0.1 - Router subnet mask = 255.255.255.0 - DHCP server: enabled - DHCP IP Address range: 100 to 200</p> <p>PC (TCP/IPv4) configuration example: - Obtain an IP address automatically In scenario2, the gateway-3D amplifier will receive an automatic IP address.</p>

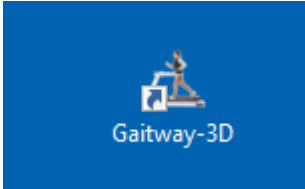
Step	Description	Comment / Illustration
3.	<p><b>Run Installer</b>                      Locate the gaitway-3D software installer provided with your device.                      Double click on the installer file to start the software installation process:                      ‘Gaitway-3D_Installer210RTE240.exe’                      Or higher version.</p>	
4.	<p><b>Installation Instructions</b>                      Follow the instructions of the Installer.                      Accept default destination directories and select Next.</p>	
5.	<p><b>Installation Instructions</b>                      Accept the license agreement and select Next.</p>	
6.	<p><b>Installation Instructions</b>                      Select Next.</p>	
7.	<p><b>Installation Instructions</b>                      After installation is complete, select finish or restart.                       If the installer requests a restart of the computer, please do so.</p>	

Step	Description	Comment / Illustration
8.	<p><b>Run software</b></p> <p>The gaitway-3D software is now installed on the computer. A shortcut/ icon can be found on the desktop and in the Programs menu.</p> <p>Double click to start the gaitway-3D software.</p> <p>The gaitway-3D software needs to access the Internet to find and download any upcoming update. If the gaitway-3D requests to access the Internet, please allow the access.</p>	
9.	<p><b>Software startup splash screen</b></p>	

#### 5.4. Switch on procedure

The gaitway-3D instrumentation supply is controlled by the same switch as the gaitway-3D treadmill supply.

	<p>More information on the switch on procedure for the gaitway-3D treadmill is available in the instructions for use of the h/p/cosmos treadmill ergometer. Please refer to the manual available at the address below:</p> <p><a href="https://www.hpcosmos.com/en/contact-support/media-downloads/manuals">https://www.hpcosmos.com/en/contact-support/media-downloads/manuals</a></p>
---	---

Once the power is established and the gaitway-3D force amplifier firmware is running, the force amplifier status led will blink once per second. The gaitway-3D software also needs to be started on the operator computer to control and readout the signals from the gaitway-3D.

	<ul style="list-style-type: none"> <li>▪ The gaitway-3D hardware shall be powered on at least 15 minutes before valid force measurements can be made.</li> </ul>
---	--

#### 5.5.

## 5.6. Switch off procedure

The gaitway-3D instrumentation supply is controlled by the same switch as the gaitway-3D treadmill supply.



More information on the switch off procedure for the gaitway-3D treadmill is available in the instructions for use of the h/p/cosmos treadmill ergometer. Please refer to the manual available at the address below:

<https://www.hpcosmos.com/en/contact-support/media-downloads/manuals>

Once the power is removed, the force amplifier status led will be switched off. The gaitway-3D software may also be closed on the operator computer.

## 5.7. Emergency stop, stop buttons, stop functions and safety features

The gaitway-3D instrumentation preserves the function of the gaitway-3D safety features such as the Emergency stop, the quick stop and pull-cord stop.



More information on the emergency stop, stop buttons, stop functions and safety features of the gaitway-3D treadmill is available in the instructions for use of the h/p/cosmos treadmill ergometer. Please refer to the manual available at the address below:

<https://www.hpcosmos.com/en/contact-support/media-downloads/manuals>

The treadmill can also be stopped from the user interface of the gaitway-3D software. The gaitway-3D software stop function is equivalent to a normal stop; the treadmill will stop as if the Stop key was pressed on the UserTerminal.

## 5.8. UserTerminal / Control Terminal

The gaitway-3D instrumentation preserves the basic functions of the gaitway-3D UserTerminal.



More information on the UserTerminal of the gaitway-3D treadmill is available in the instructions for use of the h/p/cosmos treadmill ergometer. Please refer to the manual available at the address below:

<https://www.hpcosmos.com/en/contact-support/media-downloads/manuals>

The gaitway-3D software interacts with the UserTerminal via the serial port connection using the coscom v3 or coscom v4 interface architecture as described in the h/p/cosmos documentation (cos100115v3, cos100115v4). The control of the gaitway-3D treadmill and the interaction of the gaitway-3D software with the UserTerminal are described in section 5.9.4.

## 5.9. gateway-3D software

The gateway-3D software provides a graphical user interface to allow:

- the control of the treadmill over a RS-232 serial interface;
- the control of the instrumentation amplifier via an Ethernet interface;
- the management of the information relative to the data acquisition for the gateway-3D system, such as patient and operator management, data recording, data monitoring, computation of the biomechanical parameters of locomotion, user feedback, etc.

### 5.9.1. call gateway-3D application with arguments

For specific purposes, the software can be also started from a Microsoft Windows command prompt (or a third-party application) with arguments in order to skip its main graphical user interface and lead directly to the data streaming screen and its functionalities (see section 5.9.19).

Note that the application arguments are separated by spaces and are not sensitive to capitalizations.

To directly reach the data streaming screen, call the gateway-3D software (gateway-3D.exe) with

argument1 = "streamdata";

argument2 (optional) = "simulator" or "force only" or "normal";

argument3 (optional) = any of the available activities simulated (simulator mode only), for example "walk 5 km/h" or "run 10 km/h".

Note that if argument2 is "simulator" and a simulated activity is specified as argument3, the zeroing will be handled automatically.

One example would be:

```
...\gateway-3D.exe "streamdata" "simulator" "walk 5 km/h"
```

### 5.9.2. Welcome screen and menu

After the startup splash screen, the first interface is the gateway-3D welcome screen (Figure 11). At first, the software is locked and a password needs to be entered in the top left input field **A** in order to access any software function. At this stage, the gateway-3D software is not yet connected to the gateway-3D hardware.

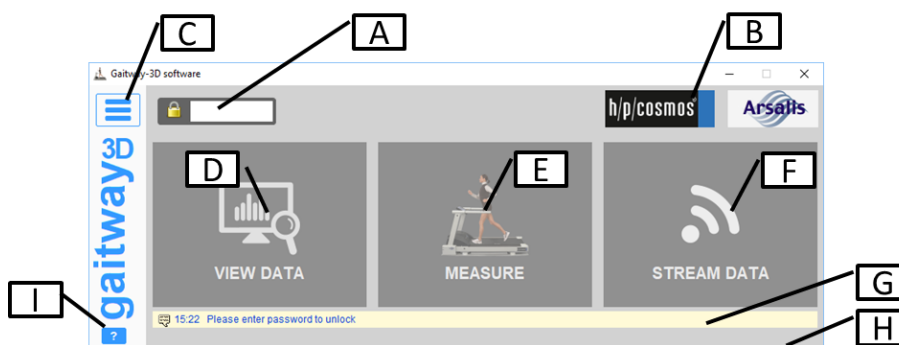

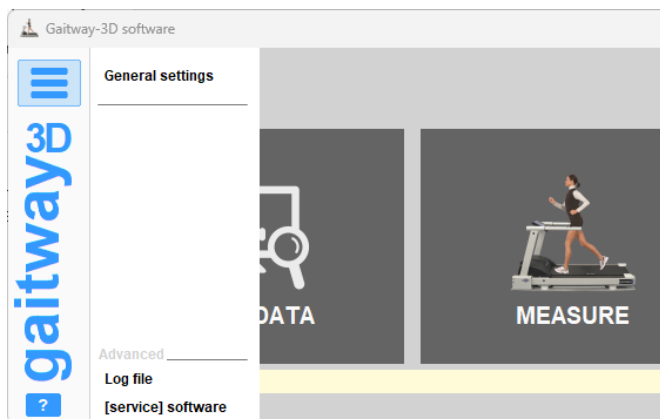

Figure 11: gateway-3D software welcome screen.

<p><b>A</b></p>	<p><b>Lock button and password entry field</b>                  Enter the password to unlock the software. The default password is <b>1234</b>.                  The password can be changed or disabled in the menu (see <b>C</b>).                  The password length must be of 1 to 6 ASCII characters.</p>
<p><b>B</b></p>	<p><b>About the software version</b>                  Click on the logos to display information about the software version currently running. Click on the links in the about gaitway-3D software window to open a text document for the software version history or web sites of the manufacturers.</p>  <p><b>Figure 12: About gaitway-3D software screen.</b></p>

**C Main menu**



The menu allows:

- Modifying the system connection parameters, the unit system (metric or imperial) and the software access lock via the “general settings” screen.

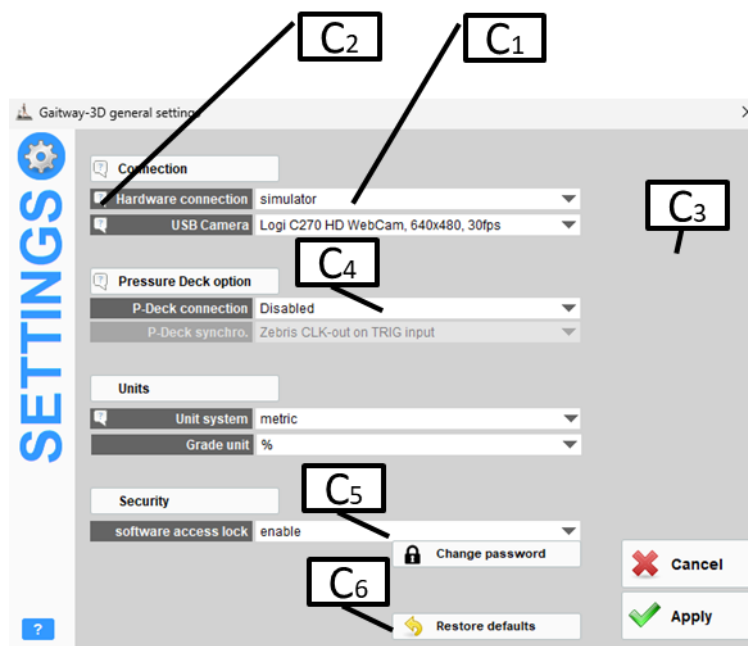

**Figure 13: gaitway-3D software general settings screen.**

C1	Click to select parameters values or enter numerical values manually. USB webcams list will be populated based on devices connected to the PC when entering the settings interface. The user can select a resolution up to 720p and a frame rate up to 60fps.
C2	Move mouse on the question marks to display help in C3.
C4	Enable/disable/setup the synchro for the Pressure Deck option which integrates the Zebris© pressure deck data into the gaitway-3D software.
C5	Enable/disable the software access lock in main window. A password prompt will be displayed when changing from “disable” to “enable”.
C6	Click this button to reset all parameters to default values.

	<ul style="list-style-type: none"> <li>▪ Displaying the Gaitway-3D software log file to view or copy all events logged by the software. The log file is limited to 1500 entries.</li> <li>▪ Enter an Activation code provided by h/p/cosmos to enable optional features. Note that the connection to the gaitway-3D will be needed to register and activate the option(s).</li> <li>▪ Access the Gaitway-3D[service] software for installation or maintenance advanced activities.</li> </ul>
<b>D</b>	<p><b><i>View data function</i></b>          Click this button to enter the View data screen.          The view data screen allows to:</p> <ul style="list-style-type: none"> <li>▪ Export the data files as native gaitway-3D format.</li> <li>▪ Export the data files as text tab-delimited files.</li> <li>▪ Open a data file for analysis.</li> </ul> <p>Refer to following sections for details on the View data screen.</p>
<b>E</b>	<p><b><i>Measure function</i></b>          Click this button to enter the measure screen.          The measure screen allows to:</p> <ul style="list-style-type: none"> <li>▪ Connect to the gaitway-3D device.</li> <li>▪ Control the treadmill.</li> <li>▪ Control the force amplifier.</li> <li>▪ Acquire and display the data in real-time.</li> <li>▪ Record data sessions.</li> <li>▪ Compute and display left and right vertical forces during walking/running.</li> <li>▪ Compute and display biomechanical statistics during walking/running.</li> <li>▪ Compute and display left and right biofeedback during walking/running.</li> </ul> <p>Refer to following sections for details on the measure screen.</p>
<b>F</b>	<p><b><i>Data Streaming function – OPTION–</i></b>          Click this button to enter the Data Streaming screen.          The Data Streaming is a software option and is activated on request.          This screen allows to:</p> <ul style="list-style-type: none"> <li>▪ Connect to the gaitway-3D device.</li> <li>▪ Control the treadmill.</li> <li>▪ Control the force amplifier via a third party application.</li> <li>▪ Acquire data and transfer calibrated data to a third party application.</li> </ul> <p>Refer to following sections for details on the Data Streaming option.</p>
<b>G</b>	<p><b><i>Status and information</i></b>          The yellow zone displays status information to the operator.</p>

<b>H</b>	<p><b>Software update</b></p> <p>If the computer is connected to the internet, the software is unlocked and a software update is available, a message appears in this bottom zone and gives the operator access to a download.</p> <p>A firmware update for the force amplifier may be part of the download. In this case, the firmware will install automatically the next time that a connection is made with the force amplifier.</p>
<b>I</b>	<p><b>Software instructions for use</b></p> <p>Click this button to open the pdf file of the instructions for use. This button can be found in all windows of the software.</p>



- Please take care that you never switch off the gaitway-3D software or the operator computer during the firmware update process. Also the Ethernet cable must not be disconnected during the firmware update process.

### 5.9.3. Measure screen: Operator, patient and settings

The gaitway-3D measure function is used to control the treadmill and measure the ground reaction forces. Before allowing these functions, the gaitway-3D software requires three pieces of information to be set:

- the operator must be identified A;
- the patient must be identified B;
- a valid connection must be established with the hardware C.

These settings are accessed via the top tiles of the measure function screen (see Figure 14).

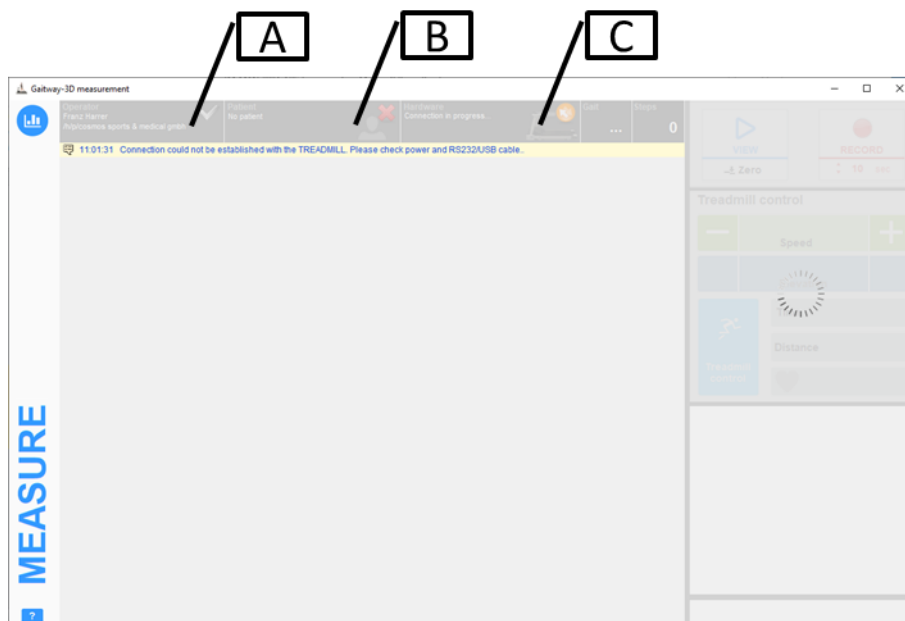
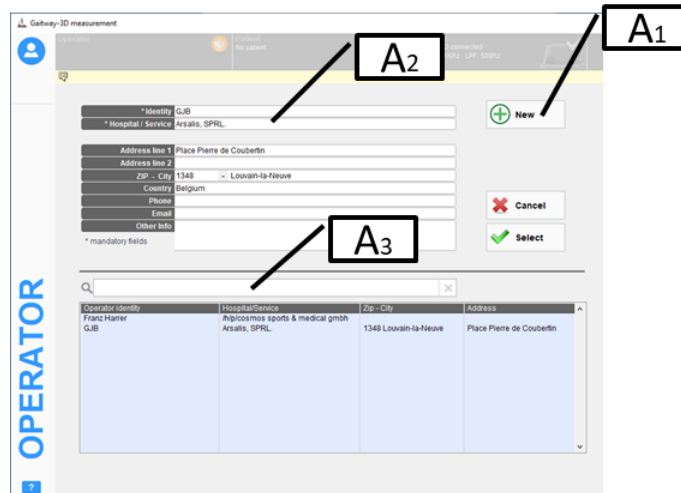

Figure 14: gaitway-3D software measure screen: Operator, patient and settings.

**A Operator**

The operator identification is managed via the operator screen ( Figure 15). This screen allows:

- the selection of an existing operator record;
- the modification of an existing operator record;
- the creation of a new operator record.



**Figure 15: gateway-3D software operator screen.**

A1	Click this button to clear all fields and create a new operator entry.
A2	Operator identity fields. The fields marked with an asterisk are mandatory fields.
A3	When operators have been created, they appear in the blue list at the bottom of the screen. You can select the operator directly in the list and you can use the search zone to filter the operators list.

**B Patient.**

The patient identification is managed via the patient screen ( Figure 16). This screen allows:

- the selection of an existing patient record;
- the modification of an existing patient record;
- the creation of a new patient record;
- measuring the weight of the patient via the weighing screen.

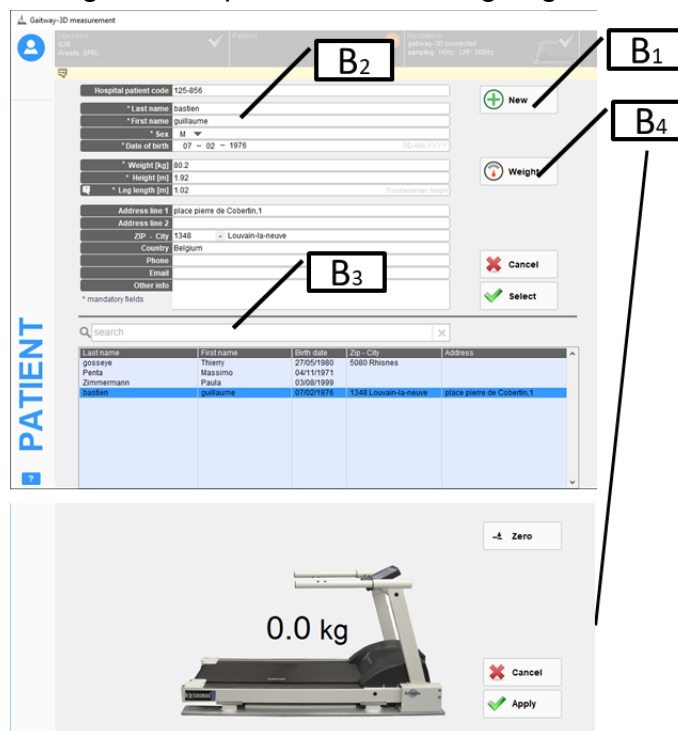

**Figure 16: gateway-3D software patient (top) and weighing (bottom) screens.**

B1	Click this button to clear all fields and create a new patient entry.
B2	Patient identity fields. The fields marked with an asterisk are mandatory fields. Note that the software auto-fills the leg length as $0.530 \times \text{Height}$ (Drillis & Contini, 1966, R 3). The value can be manually overwritten.
B3	When patients have been created, they appear in the blue list at the bottom of the screen. You can select the patient directly in the list and you can use the search zone to filter the patients list.
B4	Click this button to measure the patient weight using the weighing screen ( Figure 16 bottom).

**C Settings**

The hardware and display settings are controlled via the 'Settings' screen ( Figure 17). This screen is entered to ensure that the connection is established between the gaitway-3D software and the gaitway-3D hardware. In addition, this screen allows:

Setting the parameters of the gaitway-3D ground reaction forces (GRF):

- **Sample rate:** Sampling frequency for the forces, treadmill belt speed and digital lines. Range from 100Hz to 10kHz.
- **Records start/end:** The records can start either manually (i.e the data recording starts immediately after the "record" button is pressed), based on a digital trigger input or based on a time schedule. The digital trigger can be set on either the "Trig in" or the "Aux in" amplifier digital input. The signal edge starting the record can be either a rising or a falling edge. For auto-recordings based on a time schedule, a table can be edited with multiple recordings programmed to start at a defined activity 'Time' value reported by the treadmill.

Similarly, the records stop after a fixed amount of time (as specified under the "record" button) or based on a trigger input. In all cases, once the record is started, a click on the 'record' button stops the ongoing recording.

- **SyncOut:** the Syncout signal is a digital output of the amplifier. The Syncout signal is active (enabled) only during recordings. The SyncOut signal can be set constant (low or high) during the recording period or can pulse every N samples.

Setting the parameters of the gaitway-3D treadmill:

- **Acceleration level:** Treadmill belt speed rate when the target speed is changed in the software or user terminal. Range from 1 ("minimal", 0.03 m/s<sup>2</sup>) to 7 ("maximal", 1.66 m/s<sup>2</sup>). The highest values may be disabled depending on h/p cosmos treadmill user-terminal options.
- **Speed delay:** Delay before the treadmill belt speed changes to the new target speed set by the operator. Range from 0 to 240 seconds. If a delay is set, a beep will be emitted each second of the 5 last seconds before the speed changes to inform the patient of the forthcoming speed change.
- **Speed control:** Select "manual", "self-speed" or "virtual split belt<sup>1</sup>". If "self-speed" is enabled, the treadmill accelerates or decelerates automatically based on the patient's center of pressure position on the treadmill. The speed increases if the patient walks/runs closer to the front. The speed decreases if the patient walks/runs closer to the rear. Note that the maximal speed can be set in self-speed mode (setting available when the self-speed control is enabled). The self-speed is active only in forward belt rotation and the gait (walk or run) is detected.

If "virtual split belt" is enabled (option on request), the treadmill will accelerate and decelerate on each walking step based on a different left and right speed that can be freely and independently adjusted in the interface (up to 7 km/h). The acceleration (2-7 m/s<sup>2</sup>) and an offset (0-100%) relative to the foot strike

<sup>1</sup> Virtual split belt is an option for gaitway-3D devices equipped with MCU6 terminals, see section 5.9.16

can be set by the operator. Note that the virtual split belt is active only in forward belt rotation and the gait (walk only) is detected.

Setting the reference frame:

- Referential  $X_0;Y_0$ : coordinates, in meters, of the right-rear corner of the treadmill (default origin) relative to your referential. Refer to section 2.2.3 For detailed drawing of your device. All center of pressure values are relative to that referential. X+ is right to left axis. Y+ is rear to front axis.

Setting the parameters for the measure screen display:

- GRF filter cutoff: The cutoff frequencies, in Hertz, for the filtering of the force data. Range from 5Hz to half of the sample rate. The ground reaction forces are filtered using a 8<sup>th</sup> order Bessel low-pass filter according to the cutoff specified for each direction Z, Y and X. Default values are (Z) 30, (Y) 20, (X) 10 Hz The Bessel filter prevents any phase lag and maintains a perfect synchronization between signals. The center of pressure components, COPx and COPy are filtered according to the cutoff frequency specified for the Z direction. The free moment, Tz, is filtered according to the lowest cutoff frequency specified for the Y and X directions. The belt speed signal is also low-pass filtered using a Bessel filter with a 15Hz cutoff. A check box also allows the filter cutoff frequency of direction Z to be applied to all 3 directions.
- GRF normalization: Forces can be normalized as a percentage of the subject's body weight (%BW) instead of Newtons in Metric units or Pounds-force in Imperial units.
- Cycle normalization: The time scale and the time parameters can be normalized as a percentage of the stride or of the contact duration.
- Consecutive strides: The number of strides (left + right steps) that are overlaid or averaged in the different screens when applicable.
- Patient feedback window: When enabled, a feedback window can be displayed on a 2<sup>nd</sup> screen for the patient

Viewing the gaitway-3D amplifier information report: click on 'GRF' box;

Viewing the gaitway-3D treadmill information report: click on 'Treadmill' box.

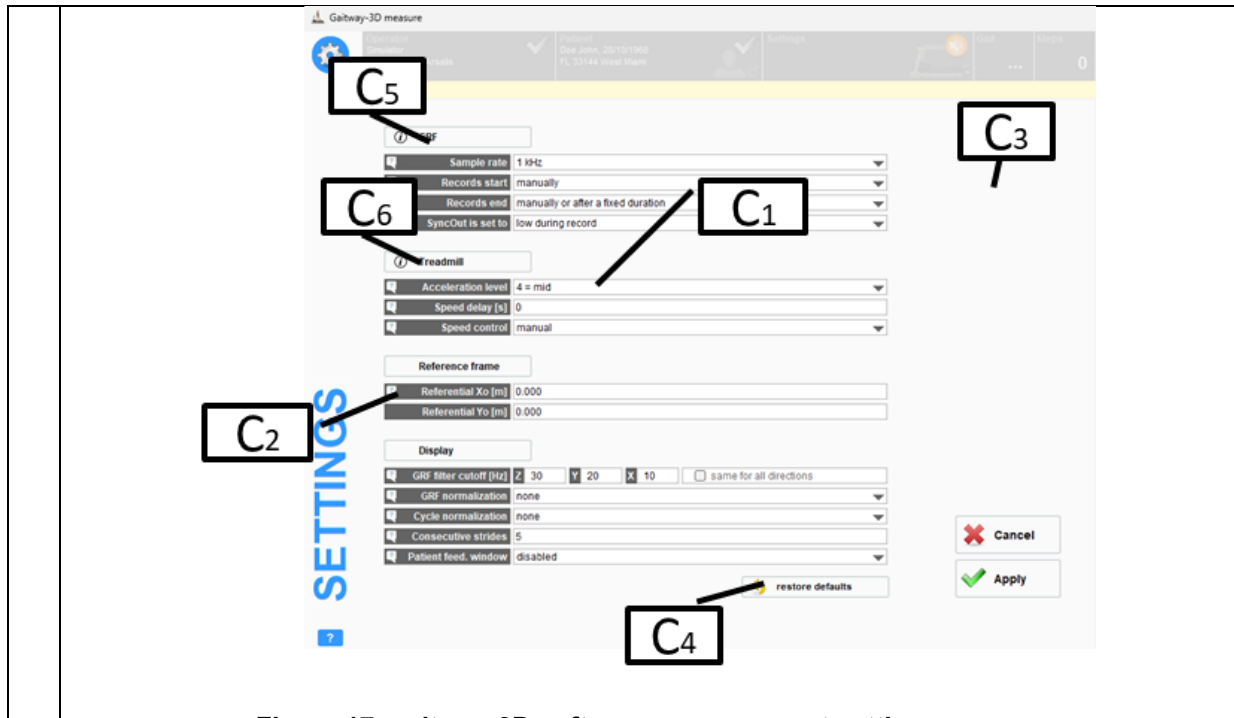



Figure 17: gaitway-3D software measurement settings screen.

C1	Click to select parameters values. Refer to the descriptions above.
C2	Move mouse on the question marks to display help in C3.
C4	Click this button to reset all parameters to default values.
C5	Click this button to display an information report about the force amplifier.
C6	Click this button to display an information report about the treadmill.



- If a valid connection to the hardware cannot be established, the software will try repeatedly to connect and the access to the settings is disabled.
- Verify power and cabling for the treadmill (see section 5.2.1).
- Verify the force amplifier is powered (see section 2.2.2.4) and verify the Ethernet cabling and settings (see section 5.2.2).

### 5.9.4. Measure screen: Treadmill control

The gaitway-3D treadmill can be controlled via the UserTerminal without restrictions.

	<p>More information on the gaitway-3D treadmill control via the UserTerminal is available in the instructions for use of the h/p/cosmos treadmill ergometer. Please refer to the manual available at the address below:  <a href="https://www.hpcosmos.com/en/contact-support/media-downloads/manuals">https://www.hpcosmos.com/en/contact-support/media-downloads/manuals</a></p>
---	--

The gaitway-3D treadmill can also be controlled via the measure screen (see Treadmill control in Figure 18). Note that an exercise started from the gaitway-3D software always starts the treadmill in manual mode. Other control modes of the treadmill (i.e. test mode, heart rate mode, profile mode) cannot be initiated from the gaitway-3D software interface. However these control modes can be started from the UserTerminal. In all modes, the treadmill control from the gaitway-3D software remains active.

Note: the treadmill control is disabled until valid connection to the gaitway-3D treadmill is established.

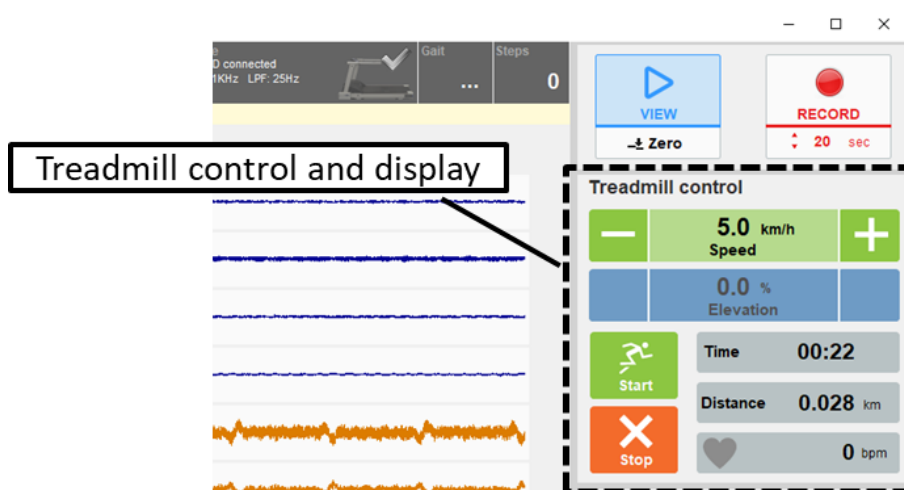

Figure 18: gaitway-3D software measure screen: Treadmill control.

The gaitway-3D software allows the following treadmill controls:

- Start (start of a manual mode exercise session);
- Stop (regular stop of the exercise session);
- Speed commands (increment, decrement, set target speed);
- Elevation<sup>1</sup> commands (up, down, set target elevation);
- Pause (button replacing 'start' or keyboard shortcut, F11);
- Cool-down (1.1 m/s, no elevation; can only be initiated with the keyboard shortcut, F10).

Two controls can be used to start the treadmill:

- Click Start button;
- Set a target speed.



If your treadmill is equipped with a MCU6 or MCU5 control unit running the coscom v4 interface, the gaitway-3D software must first request the control using the button that appears over the Start/Stop buttons and labelled “Treadmill control”. The request must then be acknowledged on the UserTerminal to allow the remote control. Note that the acknowledgement can be skipped by changing the MCU6 UserTerminal option 311 to “No”.

to stop the treadmill:

- Click Stop button.
- Click Pause button.

To set/change the treadmill speed:

- Click on Speed+ to increase speed;
- Click on Speed- to decrease speed;
- Click in the speed display and enter the target speed manually. The acceleration level is set in the hardware control screen. The speed unit is displayed on the right of the speed control/indicator. The delay (in seconds) between the command and the effective speed change can be set in the hardware control screen. If a delay is set, a beep will be emitted each second before the speed changes to inform the patient of the forthcoming speed change.

To set/change the treadmill elevation<sup>2</sup>:

- Click on Up ▲ to increase grade;
- Click on Down ▼ to decrease grade;
- Click in the elevation display and enter the target manually.

The following shortcuts are implemented in the gaitway-3D software to control the treadmill:

- F3: Speed-;
- F4: Speed+;
- F5: Down ▼ ;
- F6: Up ▲ ;
- F7: Start;
- F8: Stop;
- F10: Cool-Down;
- F11: Pause.

The list of treadmill control shortcuts can be displayed on the measure screen by placing the mouse cursor on top of the Treadmill control heading.

The gaitway-3D software displays the following treadmill indicators:

<sup>2</sup> Treadmill elevation is an option for gaitway-3D devices.

- Speed
- Elevation
- Time
- Distance
- Heart rate

The units for the treadmill displays can be changed in the 'setup' screen in main window by selecting either the metric unit system (speed in km/h and distance in km) or the imperial unit system (speed in mph, distance in miles), see section 5.9.2.

The gaitway-3D software also allows resetting the time and distance displays: Right click on Time or Distance display to see the reset option.

### 5.9.5. Measure screen: Force measure control and display

Once the gaitway-3D software has established a valid connection with the gaitway-3D hardware, the force measurement can be performed.

If a connection cannot be established, the force measure controls are disabled.



- A Zero (baseline/tare) must be performed regularly before measurement and each time elevation is changed.

A pop-up message will inform the operator that a zero is being done. No load must be applied to the treadmill while the Zero is performed, hence the patient must stand outside of the treadmill.

The ground reaction force measurement is controlled via three buttons in the top right corner of the measure screen (see Figure 19):

- View/Freeze: starts or freezes the real-time visualization of the ground reaction forces and computed parameters.
- Zero: Read the baseline signals while the system is unloaded. A pop-up message is displayed to instruct the operator that the patient must be out of the treadmill during this operation. No objects can touch the treadmill during the Zero.
- Record: starts recording the ground reaction forces signals and treadmill values in a data file. The duration of the record can be selected, in seconds, below the Record button. The Record is enabled only when a valid operator, a valid patient and a hardware connection are all present.

The sampling rate and the low-pass filtering cutoff frequencies for the force acquisition are set in the settings screen (see section 5.9.3).

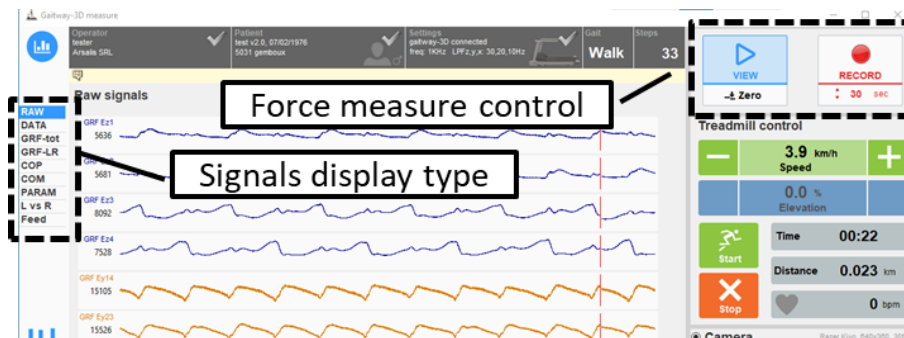

Figure 19: gaitway-3D software measure screen: Force measure control and display

Different screens are available to display the ground reaction force signals and computed parameters (see left side of the measure screen on Figure 19):

- RAW: displays the raw signals acquired by the system. 8 force channels, treadmill speed sensor and amplifier digital lines.
- DATA: displays data signals, measured and computed on two graphs.
- GRF-tot: displays the vertical, fore-aft & lateral ground reaction forces.
- GRF-LR: displays the vertical, fore-aft & lateral ground reaction forces decomposed under the left & right foot.
- COP: displays the center of pressure of the forces exerted on the locomotion surface.
- COM: displays the vertical, fore-aft and lateral displacement of the center of mass of the walking or running subject.
- PARAM: displays the biomechanical parameters for the detected gait (either walking or running).
- L vs R: displays biofeedback by comparing any biomechanical parameters for left vs. right foot. The biofeedback can be displayed on a 2<sup>nd</sup> screen for the patient.
- FEED: displays biofeedback with large numeric displays of 1 or 2 parameters computed for walking or running with customizable color zones. The biofeedback can be displayed on a 2<sup>nd</sup> screen for the patient.
- SHAKE<sup>3</sup>: displays buttons to define and send up to nine different speed perturbation profiles.

Each display screen is described with more details in the following sections.

### 5.9.6. Measure screen: RAW signals

The RAW signals screen (Figure 20) shows, from top to bottom, 13 signals acquired by the system:

- GRF Ez1: vertical force signal on front left transducer, in bits.
- GRF Ez2: vertical force signal on front right transducer, in bits.
- GRF Ez3: vertical force signal on rear right transducer, in bits.

<sup>3</sup> SHAKE is an option for gaitway-3D devices equipped with MCU6 terminals.

- GRF Ez4: vertical force signal on rear left transducer, in bits.
- GRF Ey14: fore-aft force signal on left transducers, in bits.
- GRF Ey23: fore-aft force signal on right transducers, in bits.
- GRF Ex12: lateral force signal on front transducers, in bits.
- GRF Ex34: lateral force signal on rear transducers, in bits.
- SPEED: Speed sensor measurement, in ticks.
- Sync: Sync-Out digital line, output.
- Zero: Zero digital line, input.
- Aux: Auxiliary digital line, input, can be used for triggered recordings.
- Trig: Trigger digital line, input, can be used for triggered recordings.



Figure 20: gateway-3D software measure screen: Raw signals.

<b>A</b>	<p><b>Signals</b></p> <p>The 13 signals are displayed in chart graphs. New data are displayed at the left of the red vertical line and overwrite the oldest data. The range displayed on the force signals charts and the speed signal can be adjusted with the mouse scroll-wheel to zoom in/out. The range displayed appears as tips when placing the mouse cursor on the charts. The digital signals are not scalable.</p>
<b>B</b>	<p><b>Time scale</b></p> <p>The charts can display from 1 to 15 seconds of data. This time scale can be adjusted with its '+' or '-' buttons or by placing the mouse pointer over the time scale display and using the mouse scroll-wheel to increase/decrease the time scale in steps of 1 second.</p>
<b>C</b>	<p><b>Signals scale</b></p> <p>The range displayed on the force signals charts and the speed signal can be adjusted at once with the 'FIT' or 'MAX' buttons. Use 'FIT' to auto-scale the signals and use 'MAX' to apply the full range scale.</p>

**D** **Gait and Steps counter**  
 During the exercise, the software detects if the patient is walking or running. This detection is necessary for the software to compute the appropriate biomechanical parameters and compute the forces under the left & right foot. Once the gait is identified, the steps counter reports the number of consecutive steps detected by the system. The steps count is reset when the gait type changes.

**5.9.7. Measure screen: DATA signals**

The DATA signals screen (Figure 21) shows two time-charts where one of the following signals can be displayed:

- Fz, ground reaction vertical force, in Newtons, pounds-force or %BW;
- Fy, ground reaction fore-aft force, in Newtons, pounds-force or %BW;
- Fx, ground reaction lateral force, in Newtons, pounds-force or %BW;
- COPx, center of pressure along the X (lateral) axis and relative to the reference origin, in centimeters or inches;
- COPy, center of pressure along the Y (fore-aft) axis and relative to the reference origin, in centimeters or inches;
- Tz, free moment (in the horizontal plane), in N.m or lbf.ft;
- Treadmill Speed, in km/h or mph;
- TRIG digital line;
- AUX digital line;

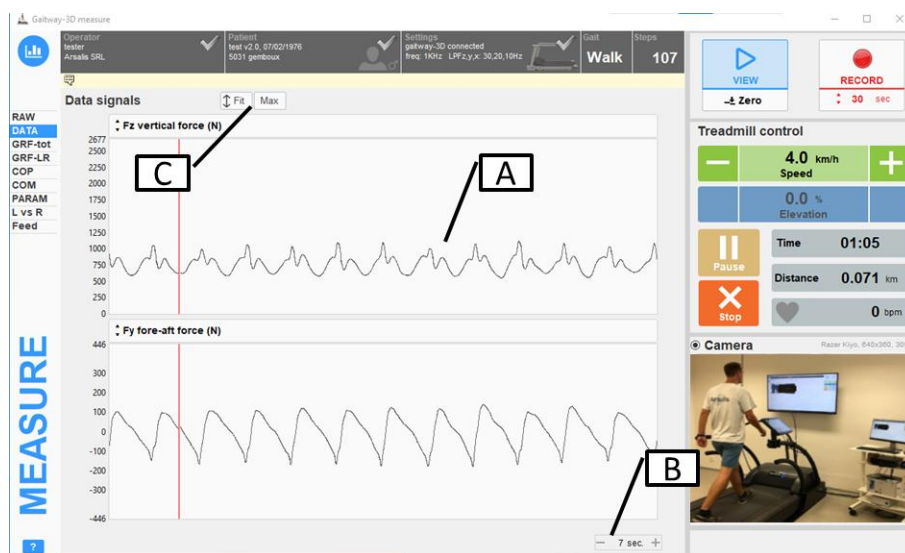

Figure 21: gateway-3D software measure screen: Data signals.

**A** **Signals**  
 The data signals are displayed in time charts. New data are displayed at the left of the red vertical line and overwrite the oldest data. The vertical scale of each chart can be adjusted with the mouse scroll-wheel to zoom in/out. The signal displayed in each chart can be selected above the corresponding chart. The data signal unit is shown in the label of the selected signal.

<b>B</b>	<b><i>Time scale.</i></b> The charts can display from 1 to 15 seconds of data. This time scale can be adjusted with its '+' or '-' buttons or by placing the mouse pointer over the time scale display and using the mouse scroll-wheel to increase/decrease the time scale in steps of 1 second.
<b>C</b>	<b><i>Signals scale</i></b> The range displayed on each chart can be adjusted at once with the 'FIT' or 'MAX' buttons. Use 'FIT' to auto-scale the signals and use 'MAX' to apply the full range scale.

### 5.9.8. Measure screen: Ground Reaction Forces

The GRF-tot screen (Figure 22) shows the following information about the total ground reaction forces:

- Fz, ground reaction vertical force, in Newtons, pounds-force or percentage of the bodyweight;
- Fy, ground reaction fore-aft force, in Newtons, pounds-force or percentage of the bodyweight;
- Fx, ground reaction lateral force, in Newtons, pounds-force or percentage of the bodyweight;



Figure 22: gateway-3D software measure screen: Ground reaction forces.

<b>A</b>	<p><b>Forces</b></p> <p>The ground reaction force signals are displayed in a time chart. New data are displayed at the left of the red vertical line and overwrite the oldest data. The scales of each chart can be adjusted with the mouse scroll-wheel to zoom in/out.</p>
<b>B</b>	<p><b>Time scale</b></p> <p>The charts can display from 1 to 15 seconds of data. This time scale can be adjusted with its '+' or '-' buttons or by placing the mouse pointer over the time scale display and using the mouse scroll-wheel to increase/decrease the time scale in steps of 1 second.</p>
<b>C</b>	<p><b>Signals scale</b></p> <p>The range displayed on each chart can be adjusted at once with the 'FIT' or 'MAX' buttons. Use 'FIT' to auto-scale the signals and use 'MAX' to apply the full range scale.</p>

### 5.9.9. Measure screen: Ground Reaction Forces, left & right

The GRF-LR screen (Figure 23) shows the following information about the ground reaction forces decomposed under each foot:

- Fz, Fy, Fx for the left foot during the contact phase, in Newtons, pounds-force or percentage of the bodyweight;
- Fz, Fy, Fx for the right foot during the contact phase, in Newtons, pounds-force or percentage of the bodyweight;
- 3D-power for the right foot during the contact phase, in Watts, or W/kg.

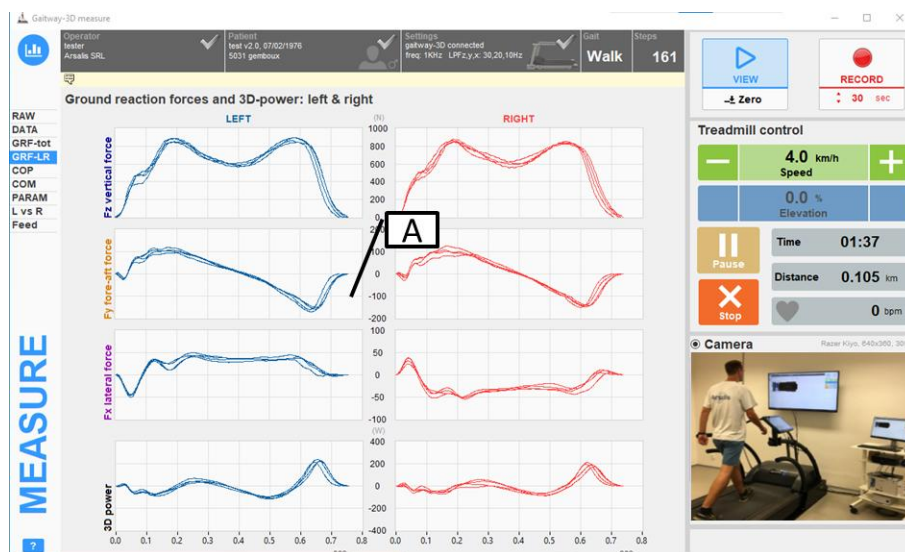

Figure 23: gateway-3D software measure screen: Ground reaction forces and 3D-power, left & right.

**A** **Vertical, fore-aft, lateral forces and 3D-power under the left & right foot**  
 In walking, the individual ground reaction forces are computed using the algorithms published in *Gait and Posture*. 2016; 43:245-250, "Determination of the vertical ground reaction forces acting upon individual limbs during healthy and clinical gait" (R 1) and in *Gait and Posture*. 2019; 73:221-227, "A robust machine learning enabled decomposition of shear ground reaction forces during the double contact phase of walking" (R 2).  
 The ground reaction forces are presented for each foot during its contact phase. From top to bottom: Vertical (Z axis), fore-aft (Y axis), lateral (X axis) ground reaction forces and 3D-power curves.  
 The 3D-power curves are computed from the 3D-forces and the 3D-speed variations of the center of mass.  
 In running, the individual vertical forces are measured during the individual contact phases.  
 The time scale of the plots automatically adjusts to the duration of the contact phase. The force scales of the plots automatically adjust to the displayed signals.

### 5.9.10. Measure screen: Center of pressure

The COP screen (Figure 24) shows the trajectory of the center of pressure during the last 2 seconds, as a XY plot, on the locomotion surface of the treadmill.

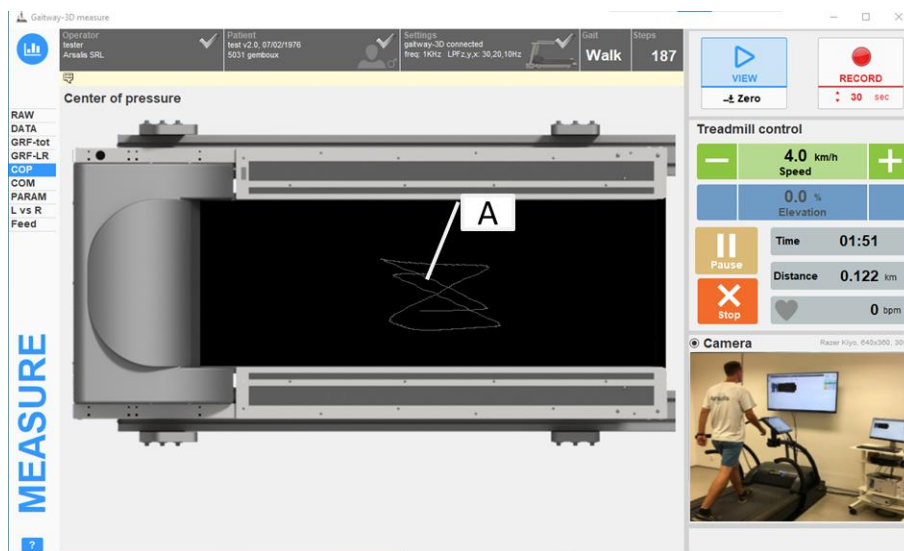

Figure 24: gateway-3D software measure screen: Center of pressure.

<b>A</b>	<p><b>COP display</b> Trajectory of the center of pressure during the last 3 steps (or 2 seconds by default), as a XY plot, on the locomotion surface of the treadmill. Note that the center of pressure is measured only when a sufficient vertical force is exerted on the treadmill.</p>
----------	---

If the Self-Speed control of the treadmill has been activated in Hardware setup (see section 5.9.3), additional cursors are displayed on the COP screen (Figure 25). To change the proportions of the ‘speed+’, ‘neutral’ and ‘speed-’ zones, grab and move the green cursors.

The position of each cursor is expressed in percentage of the walking/running area and is displayed below each cursor.

The position of the cursors can be reset to the default values using the ‘restore default zones’ button below.

During walking or running, the average position of the COP during the single stance phase will be displayed on top of the COP plot by a blue dashed vertical line. When the blue line enters the ‘speed +’ zone, the treadmill accelerates; when the blue line enters the ‘speed -’ zone, the treadmill decelerates.

Note that:

- The acceleration and deceleration are low;
- In treadmill control, the ‘speed’ term is replaced by ‘Self-speed’ when the self-speed control is active.
- The self-speed is based on step detection and is therefore inactive when the gait type is undefined;
- The self-speed is inactive when ‘VIEW’ or ‘RECORD’ is off.

- The self-speed control is reset to 'no' in hardware setup each time the application is closed.

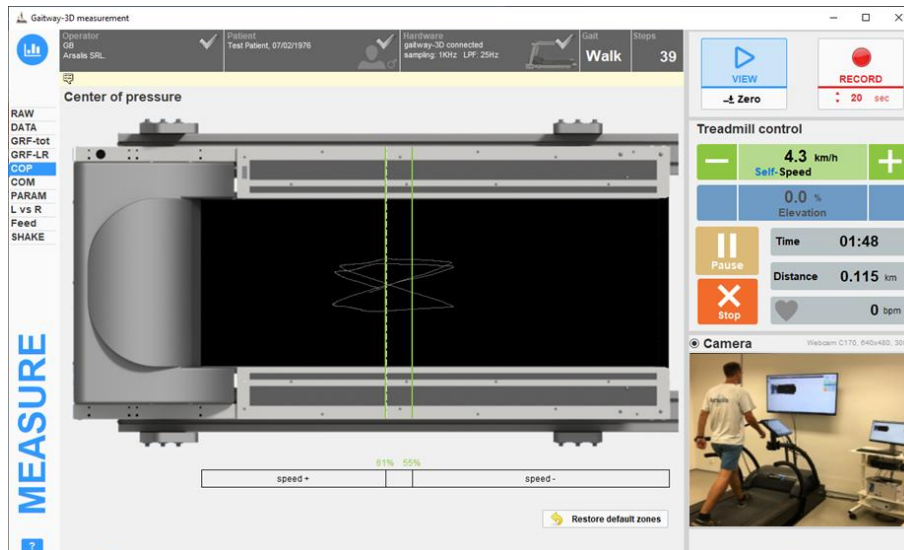

Figure 25: gaitway-3D software measure screen: Center of pressure with Self-speed.

If a Zebris pressure deck is mounted into the Gaitway-3D and the *P-Deck* option is activated and enabled, the pressure distribution under the feet is shown with the COP display (Figure 26). The Zebris data are synchronized with the 3D-Force data of gaitway-3D using the Zebris© CLK-OUT sync out cable connected to a gaitway-3D amplifier digital input. The global center of pressure measured with the pressure distribution is shown as a color cross on the graph.

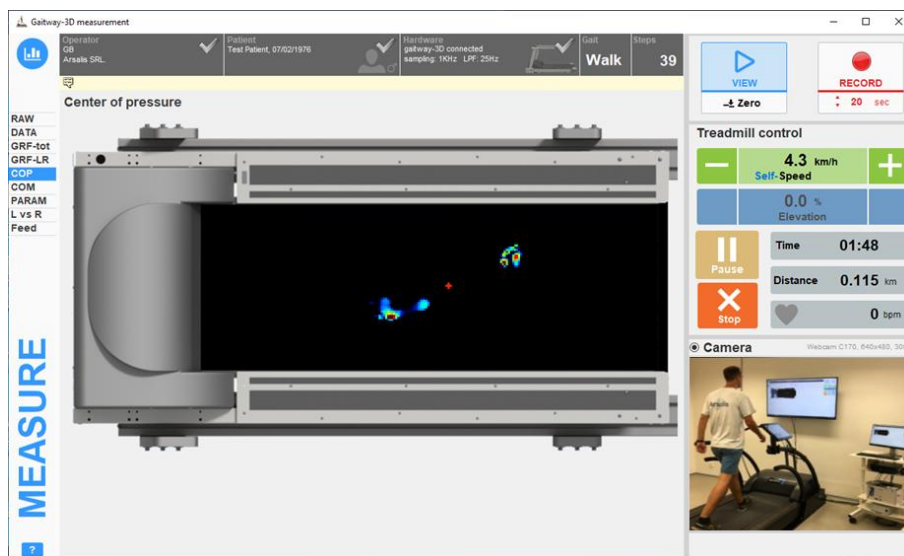

Figure 26: gaitway-3D software measure screen: Pressure deck and center of pressure.

### 5.9.11. Measure screen: Center of mass

The COM screen (Figure 27) shows the displacement of the body center of mass during consecutive strides.

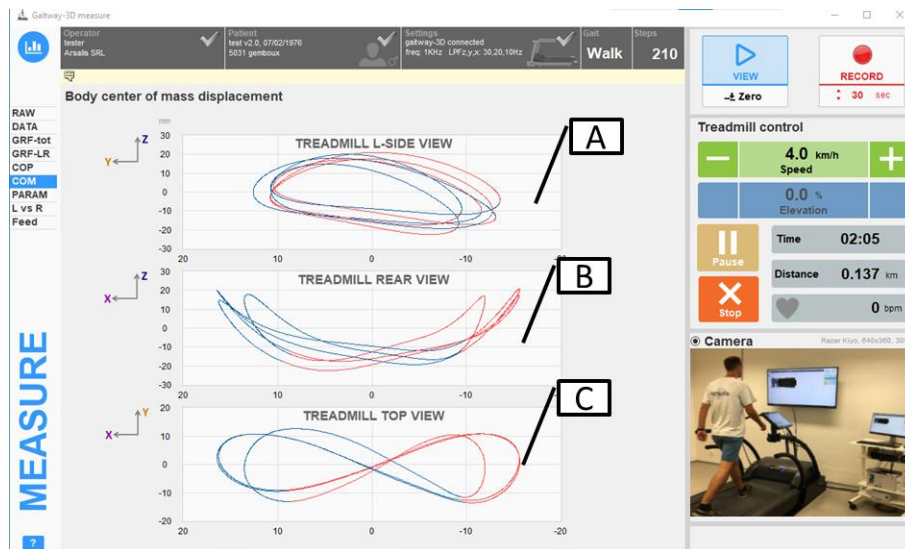

Figure 27: gateway-3D software measure screen: Center of mass.

<p><b>A</b></p>	<p><b>COM display, top graph</b>                  The graphs show the displacement of the center of mass of the subject walking or running on the treadmill.                  The first plot shows the vertical displacement of the COM as a function of its fore-aft displacement (Z vs Y axis) in the sagittal plane: left-side view.                  In blue: the center of mass displacement during left steps; In red: the center of mass displacement during the right steps; each step is recorded from a foot contact to the next foot contact. The displacement of the center of mass is computed for each stride (left + right step) and is centered in all directions on zero. All plots are auto-scaled to fit the number of strides superimposed according to the 'Consecutive strides' parameter set in section 5.9.3.</p>
<p><b>B</b></p>	<p><b>COM display, middle graph</b>                  The second plot shows the vertical displacement of the COM as a function of its lateral displacement (Z vs X axis) in the frontal plane: rear view.</p>
<p><b>C</b></p>	<p><b>COM display, bottom graph</b>                  The third plot shows the fore-aft displacement of the COM as a function of its lateral displacement (Y vs X axis) in the transverse plane: top view.</p>

### 5.9.12. Measure screen: Parameters

The PARAM screen (Figure 28) reports statistics on the biomechanical parameters measured during walking or running. The list of parameters depends on the type of gait detected and are listed below:

Walking	Running
<ul style="list-style-type: none"> <li>▪ Vertical Impulse (N.s, lbf.s, %BW.s)</li> <li>▪ Loading Rate (N/ms, lbf/ms, %BW/s)</li> <li>▪ Loading Peak Force (N, lbf, %BW)</li> <li>▪ Time to Loading Peak (ms, %stride, %contact)</li> <li>▪ Mid-Support Force (N, lbf, %BW)</li> <li>▪ Time to Mid-Support (ms, %stride, %contact)</li> <li>▪ Push-Off Peak Force (N, lbf, %BW)</li> <li>▪ Time to Push-Off Peak (ms, %stride, %contact)</li> <li>▪ Push-Off Rate (N/ms, lbf/ms, %BW/s)</li> <li>▪ L/P Peak Ratio</li>   <li>▪ Braking Impulse (N.s, lbf.s, %BW.s)</li> <li>▪ Braking Peak Force (N, lbf, %BW)</li> <li>▪ Time to Braking Peak (ms, %stride, %contact)</li> <li>▪ Time to B-P Transition (ms, %stride, %contact)</li> <li>▪ Propulsive Impulse (N.s, lbf.s, %BW.s)</li> <li>▪ Propulsive Peak Force (N, lbf, %BW)</li> <li>▪ Time to Propulsive Peak (ms, %stride, %contact)</li>   <li>▪ Lateral Strike Impulse (N.s, lbf.s, %BW.s)</li> <li>▪ Lateral Strike Peak Force (N, lbf, %BW)</li> <li>▪ Lateral Push Impulse (N.s, lbf.s, %BW.s)</li> <li>▪ Lateral Push Peak Force (N, lbf, %BW)</li>   <li>▪ 3D Collision Peak power (W, W/kg)</li> <li>▪ 3D Loading Peak Power (W, W/kg)</li> <li>▪ 3D Push-Off Peak Power (W, W/kg)</li>   <li>▪ Contact Duration (ms, %stride)</li> <li>▪ Step Duration (ms, %stride, %contact)</li> <li>▪ Double Support Duration (ms, %stride, %contact)</li> <li>▪ Single Support Duration (ms, %stride, %contact)</li> <li>▪ Duty Factor</li>   <li>▪ COM Vertical Displ. (mm, in.)</li> <li>▪ COM Fore-Aft Displ. (mm, in.)</li> <li>▪ COM Lateral Displ. (mm, in.)</li> <li>▪ COM Path (mm, in.)</li>   <li>▪ Step Length (cm, in.)</li>   <li>▪ Cadence (steps/min)</li> <li>▪ Walk Ratio (cm/spm, in/spm)</li> <li>▪ Base of Support Width (cm, in.)</li> <li>▪ Stride Duration (ms, %contact)</li> <li>▪ Mech. Work Recovery (%)</li> <li>▪ Mech. Work Total (J/m, J/kg.m)</li> <li>▪ Mech. Work Vertical (J/m, J/kg.m)</li> </ul>	<ul style="list-style-type: none"> <li>▪ Vertical Impulse (N.s, lbf.s, %BW.s)</li> <li>▪ Impact Loading Rate (N/ms, lbf/ms, %BW/s)</li> <li>▪ Active Loading Rate (N/ms, lbf/ms, %BW/s)</li> <li>▪ Impact Peak Force (N, lbf, %BW)</li> <li>▪ Time to Impact Peak (ms, %stride, %contact)</li> <li>▪ Active Peak Force (N, lbf, BW)</li> <li>▪ Time to Active Peak (ms, %stride, %contact)</li> <li>▪ Push Off Rate (N/ms, lbf/ms, %BW/s)</li> <li>▪ Leg Stiffness (N/mm, lbf/in, %BW/m, %BW/in)</li>   <li>▪ Braking Impulse (N.s, lbf.s, %BW.s)</li> <li>▪ Braking Peak Force (N, lbf, %BW)</li> <li>▪ Time to Braking Peak (ms, %stride, %contact)</li> <li>▪ Time to B-P Transition (ms, %stride, %contact)</li> <li>▪ Propulsive Impulse (N.s, lbf.s, %BW.s)</li> <li>▪ Propulsive Peak Force (N, lbf, %BW)</li> <li>▪ Time to Propulsive Peak (ms, %stride, %contact)</li>   <li>▪ Lateral Strike Impulse (N.s, lbf.s, %BW.s)</li> <li>▪ Lateral Strike Peak Force (N, lbf, %BW)</li> <li>▪ Lateral Push Impulse (N.s, lbf.s, %BW.s)</li> <li>▪ Lateral Push Peak Force (N, lbf, %BW)</li>   <li>▪ 3D Impact Peak Power (W, W/kg)</li> <li>▪ 3D Propulsion Peak Power (W, W/kg)</li>   <li>▪ Contact Duration (ms, %stride)</li> <li>▪ Step Duration (ms, %stride, %contact)</li> <li>▪ Aerial Duration (ms, %stride, %contact)</li> <li>▪ Duty Factor</li>   <li>▪ COM Vertical Displ. (mm, in.)</li> <li>▪ COM Fore-Aft Displ. (mm, in.)</li> <li>▪ COM Lateral Displ. (mm, in.)</li> <li>▪ COM Path (mm, in.)</li>   <li>▪ Step Length (cm, in.)</li>   <li>▪ Cadence (steps/min)</li> <li>▪ Base of Support Width (cm, in.)</li> <li>▪ Stride Duration (ms, %contact)</li> <li>▪ Mech. Work Total (J/m, J/kg.m)</li> <li>▪ Mech. Work Vertical (J/m, J/kg.m)</li> <li>▪ Mech. Work Fore-aft (J/m, J/kg.m)</li> </ul>

- Mech. Work Fore-aft (J/m, J/kg.m)
- Mech. Work Lateral(J/m, J/kg.m)

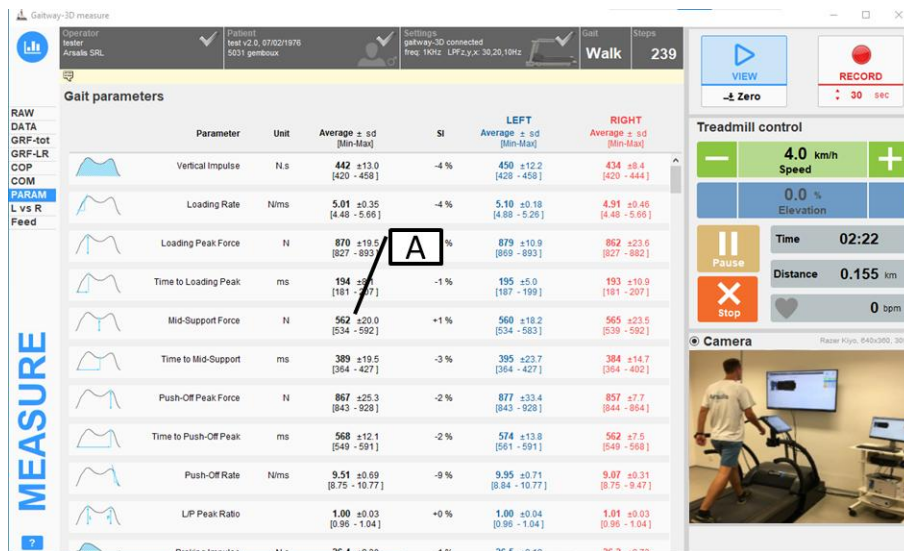

Figure 28: gaitway-3D software measure screen: Parameters.

**A Statistics table**

The table reports the average, standard deviation, minimum and maximum values for each parameter calculated on the number of consecutive strides as selected in Hardware settings (see section 5.9.3). Each parameter is accompanied by an illustration. The list of parameters reported in the table depends on the gait detected by the system. The table reports values for the whole stride(s) in black, for the left step(s) in blue and for the right step(s) in red. The table also reports the symmetry index (SI), showing the percentage difference between the left (L) and the right (R) steps. A positive SI means that the right step(s) value is greater than the left step(s) value. The SI is computed as:  $SI = [(R-L)/0.5*(R+L)] * 100$  Patterson et al., 2010, R 4.

### 5.9.13. Measure screen: Left vs Right

The L vs R screen (Figure 29) reports a biomechanical parameter measured for left steps versus the same parameter measured for right steps during walking or running. The parameter can be selected in the list of parameters for the corresponding gait.

independently from the operator’s screen, the L vs R screen can be duplicated on a 2<sup>nd</sup> screen for the patient. Enable it in the Settings, see section 5.9.3

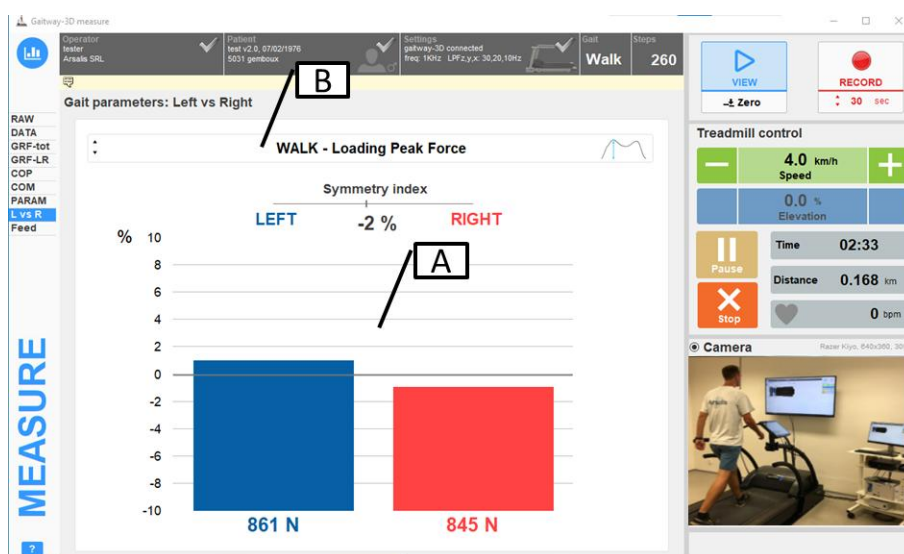

Figure 29: gaitway-3D software measure screen: Left vs Right biofeedback.

<p><b>A</b></p>	<p><b>Bar plot</b>                  The graph reports the selected parameter measured on left steps in blue versus the same parameter measured on right steps in red. Parameters are expressed in percentage to compare left and right steps. If the parameter is the same for the left and the right step, the value is 50% for each. The vertical scale can be adjusted with the mouse scroll-wheel to zoom in/out. The reported value is the average calculated on the number of consecutive strides as selected in Hardware settings (see section 5.9.3). The average value for each side is reported below each bar. A symmetry index is calculated and displayed below the bars. The symmetry index (SI) shows the percentage difference between the left (L) and the right (R) steps. A positive SI means that the right step(s) value is greater than the left step(s) value. The SI is computed as: <math>SI = [(R-L)/0.5*(R+L)] * 100</math>                  Patterson et al., 2010, R 4.</p>
<p><b>B</b></p>	<p><b>Parameter selection</b>                  The parameters list depends on the gait detected by the system.</p>

### 5.9.14. Measure screen: Feedback

The Feedback screen (Figure 31) reports one or two biomechanical parameters with a configurable target colored zone and a large numeric display.

independently from the operator’s screen, the Feedback can be duplicated on a 2<sup>nd</sup> screen for the patient. Enable it in the Settings, see section 5.9.3

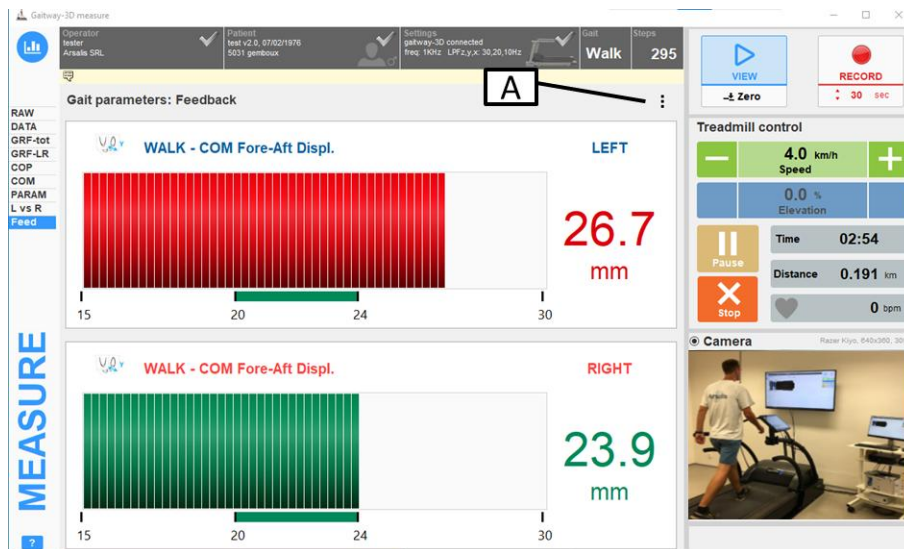

Figure 30: gateway-3D software function screen: Feedback (1).

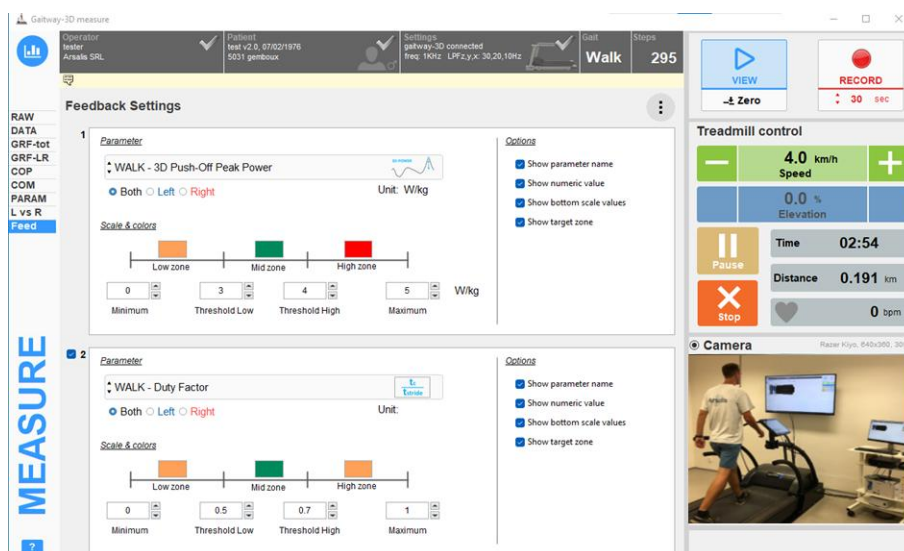

Figure 31: gateway-3D software function screen: Feedback (2).

**A Feedback Settings**  
 Click on the 3 vertical dots to access the settings for each feedback. Parameter, limits, colors, side and display options can be customized.  
 On the left side, use the checkbox to determine if parameter must be shown.



### 5.9.15. Measure screen: SHAKE<sup>4</sup>

The SHAKE screen is the interface to send sudden speed perturbations to the treadmill. If the SHAKE option is not activated this screen is not accessible. A perturbation is defined by a profile of treadmill speed. Up to nine different perturbation profiles can be edited, saved and sent to the treadmill. The perturbations use the fastest feasible acceleration of the treadmill belt to change to a target speed and hold it for a defined period of time. After a perturbation, the speed remains at the last speed setting of the perturbation. Perturbations are either manually run or triggered relative to a left, right or to any foot contact.

The perturbation profiles are saved in the folder.\programData\Arsalis\Gaitway-3D\Gaitway-3D PerturbationProfiles as XML files. Those files are loaded into the MCU6 when entering the SHAKE screen for the first time (per session) or when they are edited or created. Note that the treadmill must be stopped to load the profile(s) into the MCU6.

Note that safety instructions must be accepted with a valid pin code on the MCU6 user terminal in order to activate the perturbation mode.

MCU6 perturbation activation code pin: 3996

	<div data-bbox="683 1048 1136 1243"></div> <ul style="list-style-type: none"><li>▪ The perturbation function mode (module) is extremely powerful and can be very dangerous if precautions would be disregarded.</li><li>▪ Incorrect perturbation operation, forbidden use and/or over exercising may result in falling, serious injury or death and will result in loss of any liability and warranty.</li><li>▪ Prescribed fall prevention device is required for any applications with perturbation. A safety lanyard (pull cord device with magnet clip, etc.) is not considered to be sufficient to prevent from falling!</li><li>▪ Only carefully trained medical staff is allowed to use the device and to decide about perturbation level and operation.</li><li>▪ Do not use perturbation for subjects and/or patients with osteoporosis or subjects where sudden accelerations and/or decelerations may cause injury to muscles, joints or bones.</li></ul>
---	---

<sup>4</sup> SHAKE is an option for gaitway-3D devices equipped with MCU6 terminals.



Figure 32: gateway-3D software measure screen: SHAKE (1).

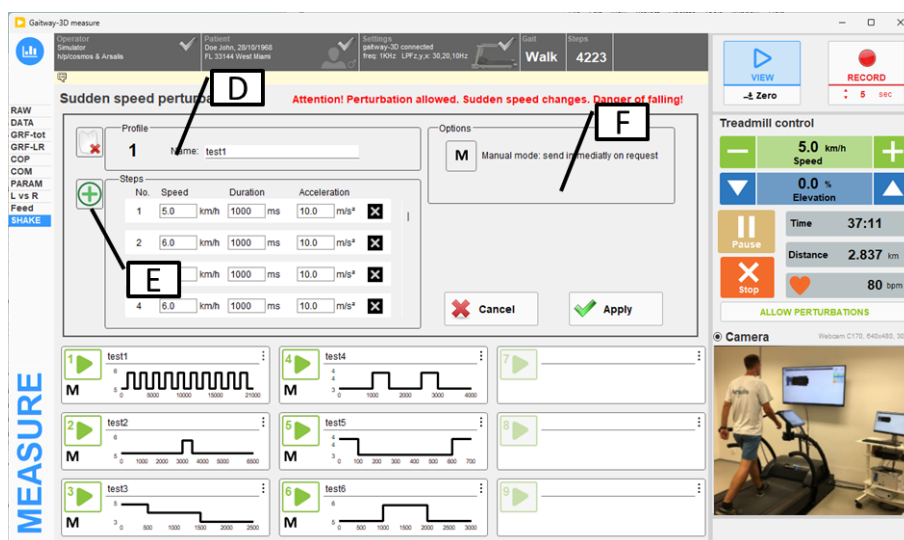

Figure 33: gateway-3D software measure screen: SHAKE (2).

<p><b>A</b></p>	<p><b>Graph</b> One signal can be displayed as a time chart (as in the DATA screen, see section 5.9.7). Use the selector above the chart to choose the signal, use the signals scale 'FIT' and 'MAX' buttons and the time scale control below the graph to change the display.</p>
<p><b>B</b></p>	<p><b>Perturbation controllers</b> Nine controllers are available to save and send each perturbation profile. Each controller is numbered from 1 to 9. The controller is made of a button (top left of the controller) to start the perturbation profile; the triggering options of the perturbation (bottom left, under the start button); a profile name (on the right of the start button); a profile graphical overview (below the profile name) and a 'Edit' button (3 dots) to display the profile editor/creator (on top right corner of the controller).</p>

<b>C</b>	<p><b><i>Allow/Disable Perturbations control</i></b>                  To run a perturbation from gaitway-3D, the external control must be requested and granted by the MCU but also the perturbation mode must be allowed. Note that a safety pin code will be requested on the MCU (refer to h/p/cosmos documentation). Once perturbation profiles are allowed, the 'DISABLE PERTURBATION' button will be shown to immediately cancel the ongoing perturbation and prevent any new perturbation profile.</p>
<b>D</b>	<p><b><i>Perturbation editor</i></b>                  Clicking the 'Edit' button on top right of any perturbation controller, opens the perturbation profile editor above the controllers, in place of the signal time chart. Each profile is numbered automatically and must have a name. To delete, clear a profile, click the 'Clear profile' button on the left of the profile number. After setting the name, the steps and options of the profile, press Apply to save the profile and send it to the MCU6 treadmill controller in order to make the perturbation ready to use. Note that the treadmill must be stopped to load the profile(s) into the MCU6.</p>
<b>E</b>	<p><b><i>Perturbation editor: steps</i></b>                  Each perturbation profile must have at least one step, defining the target speed to reach, the duration of the change in milliseconds and the acceleration of the belt in m/s<sup>2</sup>. Press the '+' button on the left to add a step to the profile.</p>
<b>F</b>	<p><b><i>Perturbation editor: options</i></b>                  Each perturbation profile can start either manually, as soon as its start button is pushed (select 'M') or can be initiated by a left foot contact during walking or running gait (select 'L'); by a right foot contact (select 'R') or any first foot contact following the start (select 'A'). In addition, a delay can be added between the foot contact and the beginning of the perturbation.</p>

### 5.9.16. Measure screen: Virtual split belt<sup>5</sup>

The Virtual split belt mode can be activated from the speed control selector (see settings 5.9.3. Once the virtual split belt mode is selected, new speed controllers will appear at the top of the treadmill control pane for controlling individually the treadmill speed during the left foot strikes and during the right foot strikes.

If the option is not activated, the speed control as virtual split belt is not accessible.

With virtual split belt mode active, the treadmill will accelerate and decelerate on each walking step based on a different left and right speed that can be freely and independently adjusted in the interface (up to 7 km/h). The acceleration (2-7 m/s<sup>2</sup>) and an offset (0-100%) relative to the foot strike can be set by the operator. Note that the virtual split belt is active only in forward belt rotation and only when a walking gait is detected.

<sup>5</sup> Virtual split belt is an option for gaitway-3D devices equipped with MCU6 terminals.

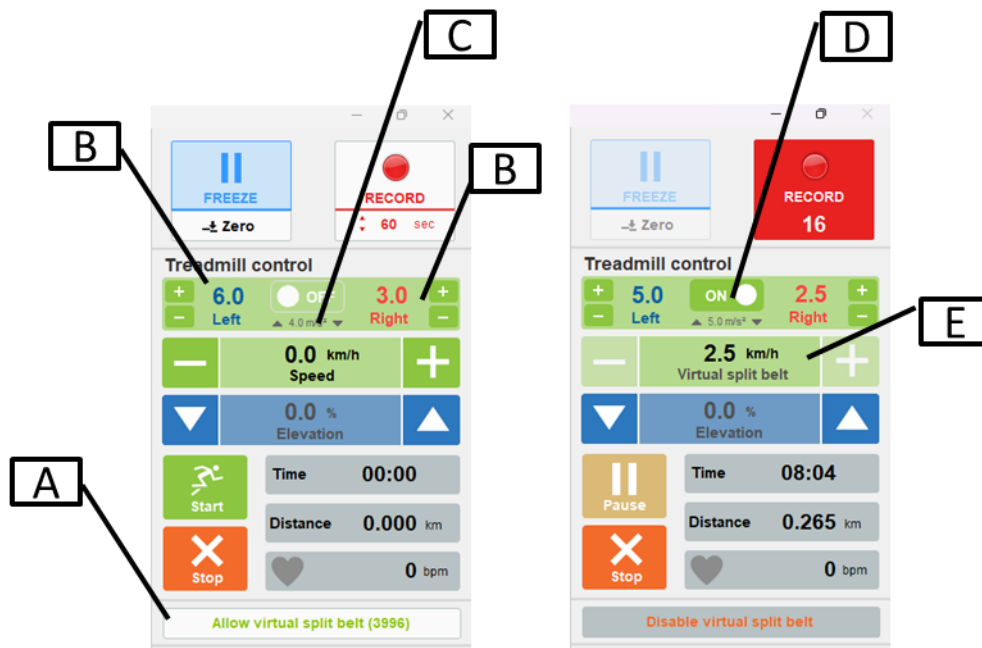

Figure 34: gateway-3D software measure screen: Virtual split belt.

Note that safety instructions must be accepted with a valid pin code on the MCU6 user terminal in order to activate the ‘high-acceleration’ mode.

MCU6 high-acceleration activation code pin: 3996

	 
	<ul style="list-style-type: none"> <li>▪ Prescribed fall prevention device is required for any applications with virtual split belt. A safety lanyard (pull cord device with magnet clip, etc.) is not considered to be sufficient to prevent from falling!</li> <li>▪ Only carefully trained operators are allowed to use the device and to decide about speed and acceleration level.</li> </ul>

<p><b>A</b></p>	<p><b><i>Allow/Disable virtual split belt</i></b></p> <p>To drive the treadmill in virtual split belt mode from gateway-3D, the external control must be requested and granted by the MCU but also the ‘high acceleration’ mode must be allowed. Note that a safety pin code will be requested on the MCU (refer to h/p/cosmos documentation). Once high-acceleration profile is allowed, the ‘Disable virtual, split belt’ button will be shown to cancel the ongoing virtual split mode and disallow the MCU ‘high acceleration’ profile.</p>
-----------------	---

<b>B</b>	<p><b>Virtual split belt speed</b></p> <p>The target speed for the Left and for the Right foot strikes can be edited at any time once the treadmill control from the Gaytway-3D software has been acknowledged. Speed values are limited to a maximum of 7 km/h. Individual target speeds can be edited even while the virtual split belt is active. On the contrary, as long as the virtual split belt activation button (<b>D</b>) is off, the speeds can be adjusted without direct influence on the real treadmill speed.</p>
<b>C</b>	<p><b>Virtual split belt acceleration</b></p> <p>The acceleration can be chosen between 2 and 7 m/s<sup>2</sup>. The acceleration is higher than the normal range of acceleration for the treadmill in order to have fast changes between the ‘left’ and the ‘right’ speed. The higher the acceleration, the sharper the speed change. The lower the acceleration, the smoother is the speed change.</p> <p>The choice of acceleration and the difference between the left and the right speed directly define the duration of the speed change.</p> <p>We highly recommend to use lower accelerations (2-4 m/s<sup>2</sup>) when the difference between the left and the right speeds is elevated.</p>
<b>D</b>	<p><b>Virtual split belt ON/OFF</b></p> <p>Use the ON/OFF button to start-stop the virtual split belt mode (VSB). The VSB can be started when:</p> <ul style="list-style-type: none"> <li>- The treadmill control is allowed</li> <li>- The virtual split belt mode is enabled (see <b>A</b>)</li> <li>- A subject walks on the treadmill and the gait is detected by the software.</li> </ul> <p>When the VSB is set ON, the speed will change independently for each step. The algorithm is anticipating the next foot strike of the subject and controls the speed such that the front foot contact happens at the middle (50%) of the speed change. This synchronization of the speed change and the front foot contact, expressed in % of the speed change duration, can be modified in the speed control settings between 0 and 100% (see section 5.9.3). 0% = speed starts to change at the instant of the foot contact. 100% = the speed change ends at the instant of the foot contact. Default = 50%.</p> <p>When the VSB is set OFF, the algorithm will always end on the lowest speed between the left and right speed targets and then slowly return to the treadmill speed that was set before the VSB was initiated.</p>
<b>E</b>	<p><b>Current speed display</b></p> <p>When the VSB is ON, the classic speed display does not behave anymore as a speed controller (disabled buttons and speed entry) but shows the current speed and thus varies at each step. In this case ‘virtual split belt’ is written below the digital speed indicator rather than ‘speed’.</p>

**5.9.17. Measure screen: Recording**

During a record, the data are displayed and also saved to a binary data file. At the end of the recording, the display stops and the Record panel appears on the right of the screen (Figure 35).

The operator can enter additional information concerning the record and select to either confirm the record saving or discard the record. The measurement is disabled until the operator has clicked on the ‘Save’ or ‘Discard’ button.

Note that automatic tags are created at save time and are part of the data file: the exercise type (walking or running), the speed and the recording time. Those tags are shown in the records listing previewer (see next section). Therefore it is not necessary to write these items as manual comments.

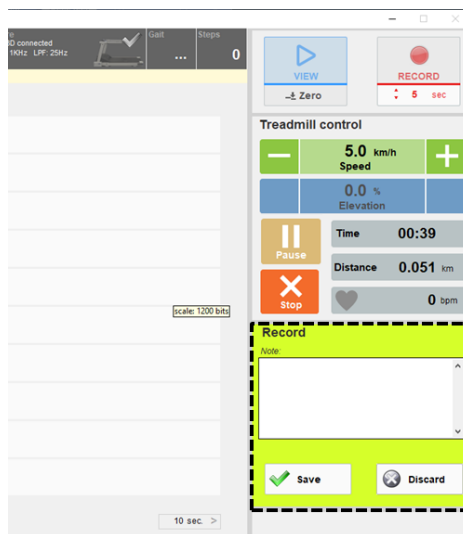

Figure 35: gaitway-3D software measure screen: Record confirmation.

### 5.9.18. Measure screen: Video camera

A USB video camera (DirectShow® compatible), typically a USB webcam, can be connected, displayed and recorded in the gaitway-3D software.

Once the camera has been recognized and selected in the welcome screen menu (see section 5.9.2, C), the video will be displayed in the right panel of the Measure screen, below the treadmill control area (Figure 36). Above the video, a switch button allows to set the USB camera on/off.

The camera is automatically setup to have a constant frame rate, typically 30fps or 60fps depending on the camera capability. This camera configuration is displayed above the video. Note that the video display in this screen is rescaled to fit the area. All other settings can be done manually by right clicking the image and selecting “Camera settings”: A new screen for camera settings will be displayed with the available settings and the video reflecting any change applied to the camera settings such as gain, gamma, sharpness, etc. (Figure 37).

Note that the images can also be rotated if a vertical image is preferred for the setup.

During a data record, the video will be recorded and saved to file in a compressed avi file format.

Note that it is also possible to hide the camera during recordings to reduce the CPU display time and keep up with the desired frame rate. This option can be set in the camera settings.

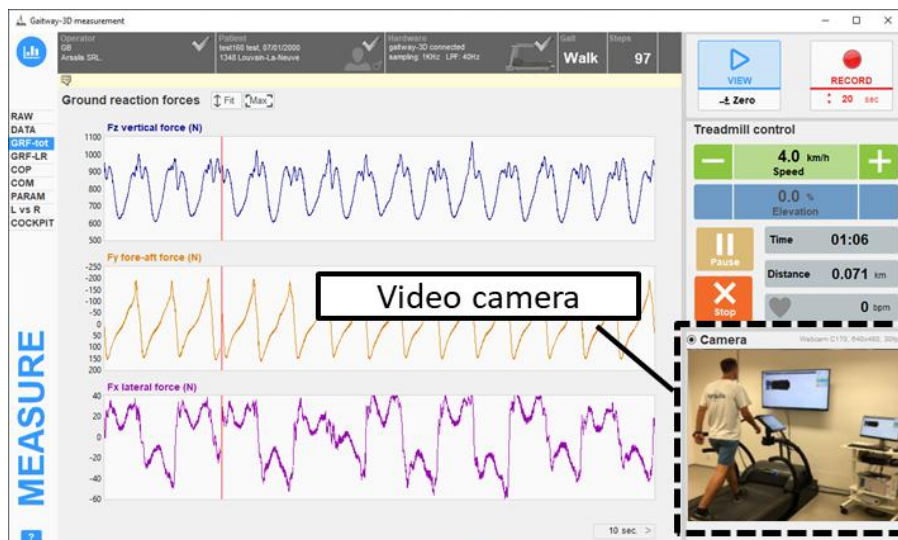

Figure 36: gaitway-3D software measure screen: Video camera display.

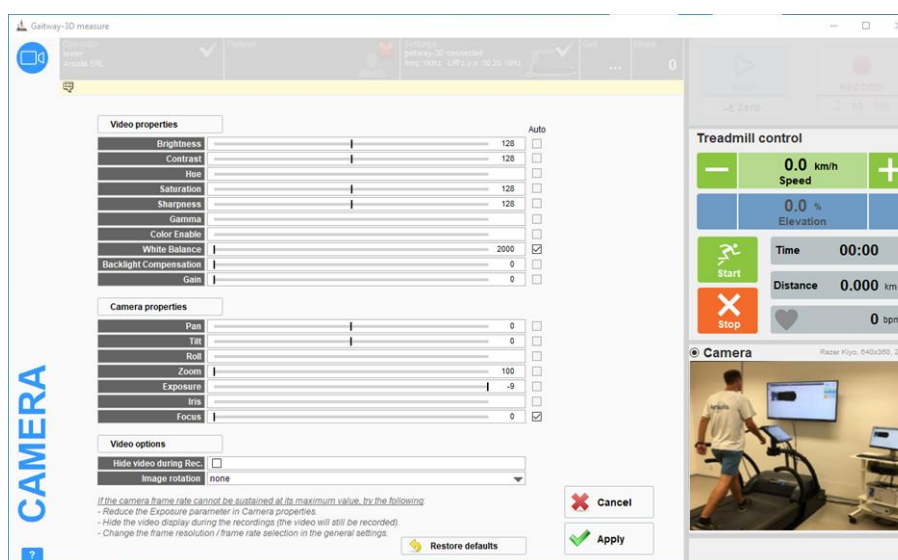

Figure 37: gaitway-3D software measure screen: Video camera settings.

### 5.9.19. Data stream screen

The Data streaming function is an option of the gaitway-3D software. If the option is activated for your device, the function is intended to transmit calibrated force signals to a third party application that will display and interpret the signals synchronously with other signal sources. The data streaming function relies on a proprietary software interface control documented by Arsalis and uses a TCP/IP port.

The data streaming screen (Figure 38) allows to:

- control the treadmill in the same way as in the Measure screen (see section 5.9.4);
- display the connection status with the third party application (*i.e* the client);
- configure the force amplifier for the data streaming activity;
- display the streaming activity based on the commands received from the client.

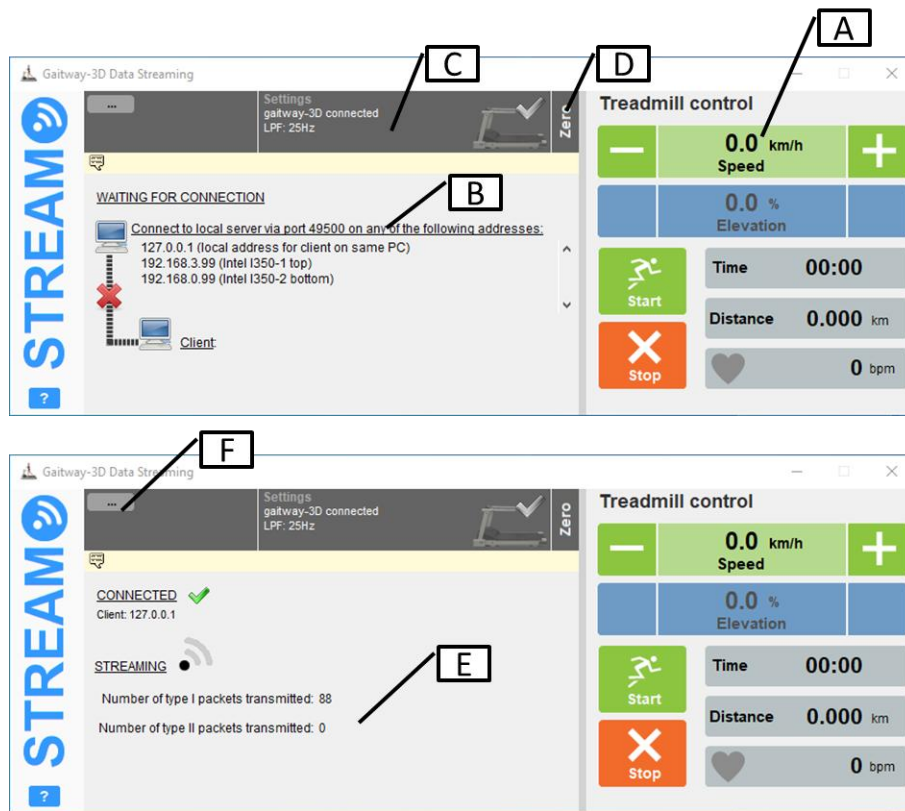

Figure 38: gaitway-3D software data streaming screen.

<p><b>A</b></p>	<p><b>Treadmill control</b> Refer to section 5.9.4 for a complete description of the treadmill control.</p>
<p><b>B</b></p>	<p><b>Available connections</b></p> <p><u>IMPORTANT:</u> The local server displayed on the screen is a list of potential IP addresses and port (49500) to be configured on the client interface to establish a connection with Gaitway-3D.</p> <p>If the client software is running on the same computer as the gaitway-3D software, it is recommended to use the generic 'localhost' IP address &lt;127.0.0.1&gt;.</p> <p>If the client software is running on another computer: First, an Ethernet adapter in both computers (client and local) must be connected in an Ethernet network. Second, configure the settings of both adapters to use the same subnet. Third, select the Ethernet adapter for Data Streaming that has been connected to the client software.</p> <p>When the client software connects correctly to the gaitway-3D software data streaming interface, the connection status is updated and the interface changes to show the streaming activity.</p>
<p><b>C</b></p>	<p><b>Settings</b> Click this area to open the gaitway-3D settings screen for data streaming (Figure 39).</p>

The available GRF settings are:

- Triggering configuration: the trigger is enabled or disabled by the command of the third-party application. The settings, here, apply only when the start and/or stop trigger are enabled by the third-party application command. Refer to the documentation provided by your third-party application to enter the correct settings.
- SyncOut: the Syncout signal is a digital output of the amplifier. The Syncout signal is enabled or disabled by the command of the third-party application. The settings, here, apply only when the SyncOut is enabled by the third-party application command; The SyncOut signal can be set constant (low or high) or can pulse every N samples.
- Fz-threshold for COP: by default, the gaitway-3D software computes the center of pressure when the vertical force is above 150N in running and above 50N in walking. Thresholding can be cancelled for the data-stream. In the latter case, the center of pressure is computed at any time, regardless of the applied force. It will be up to the third-party application to threshold the COP signals.
- GRF filtering: The forces in Z, Y, X can have independent cutoff frequencies, in Hertz, for the filter. Range from 5Hz to half of the sample rate. The ground reaction forces are filtered using a 8<sup>th</sup> order Bessel low-pass filter according to the cutoff specified for each direction Z, Y and X. Default values are (Z) 30, (Y) 20, (X) 10 Hz. The Bessel filter prevents any phase lag and maintains a perfect synchronization between signals. The center of pressure components, COPx and COPy are filtered according to the cutoff frequency specified for the Z direction. The free moment, Tz, is filtered according to the lowest cutoff frequency specified for the Y and X directions. The belt speed signal is also low-pass filtered using a Bessel filter with a 15Hz cutoff.

The available Reference frame settings are:

- Referential Xo;Yo: coordinates, in meters, of the right-rear corner of the treadmill (default origin) relative to the referential used by the third-party application . X+ is right to left axis. Y+ is rear to front axis. Refer to the documentation provided by your third-party application to enter the correct settings.

The available treadmill settings are:

- Acceleration level: Treadmill belt speed rate when the target speed is changed in the software or user terminal. Range from 1 ("minimal", 0.03 m/s<sup>2</sup>) to 7 ("maximal", 1.66 m/s<sup>2</sup>). The highest values may be disabled depending on h/p cosmos treadmill user-terminal options.
- Speed delay: Delay before the treadmill belt speed changes to the new target speed set by the operator. Range from 0 to 240 seconds. If a delay is set, a beep will be emitted each second of the 5 last seconds before the speed changes to inform the patient of the forthcoming speed change.
- Self-speed control: If enabled, the treadmill accelerates or decelerates automatically based on the patient center of pressure position on the treadmill. The speed increases if patient walks/runs closer to the front. The speed decreases if patient walks/runs closer to the rear. Note that the

maximal speed in self-speed mode is settable (the max self-speed setting is available when the Self-speed control is set to “yes”). The self-speed is active only in forward belt rotation, during data streaming and the gait (walk or run) is detected.

All settings apply specifically to the data streaming environment.

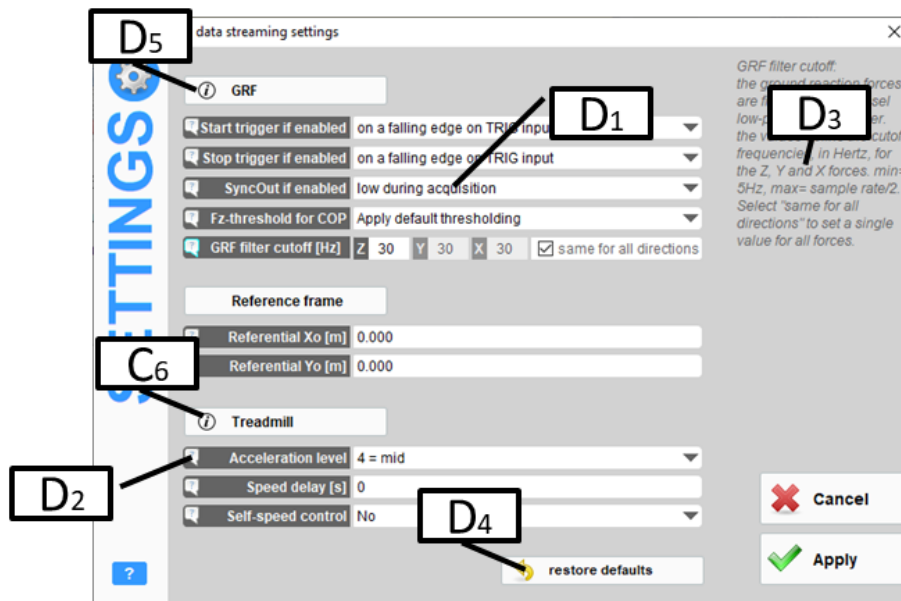

Figure 39: gateway-3D settings screen for data streaming.

D1	Click to select parameters values. Refer to the descriptions above.
D2	Move mouse on the question marks to display help in D3.
D4	Click this button to reset all parameters to default values.
D5	Click this button to display an information report about the force amplifier.
D6	Click this button to display an information report about the treadmill.

**D Zero**  
Click this button to reset the force signal baseline. This action can also be done remotely by the client.

**E Streaming**  
This section displays the streaming activity. When a streaming activity is ongoing, an animated icon shows up and the number of packets transmitted is displayed. Two types of data packets can be transmitted depending on the command sent by the client software.

**F Gait & system Info**  
This section displays the gait activity detected (walk, run, none) and the P-DECK tag if the P-Deck option is activated and enabled, showing that the pressure data are received, synchronized and used for the individual left-right COP measurement.

### 5.9.20. Records list

All recordings listed in the Gaitway-3D records screen (Figure 40) can be opened for analysis or exported as:

- Native binary file format for gaitway-3D. Those files can only be read with the gaitway-3D software.
- ASCII tab-delimited text files. Those files can be read by any text editor and table editors such as Microsoft Excel. The decimal separator is a dot.

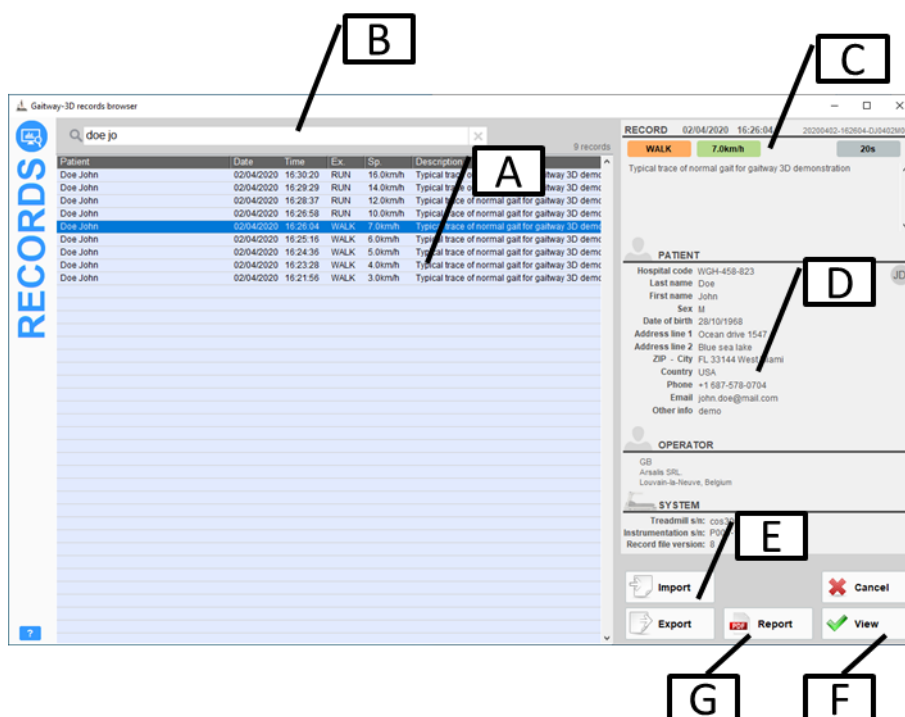

Figure 40: gateway-3D software records listing.

A	<p><b>Records list</b>                  To export: Select one or multiple records in the list.                  Use mouse click +SHIFT or +CTRL keys for multiple selection.                  To open and analyze: Select one single file and click the ‘View’ button.</p>
B	<p><b>Search</b>                  Use the search zone to filter the records list. The search is based on items shown in the records list. use “+” sign to combine multiple terms for the search function.                  The last five search entries are kept in memory. Use the up/down arrows to call back previous entries and navigate through them.</p>
C	<p><b>Record description</b>                  When a single record is selected in the list, this section shows the date of creation, the tags for the gait type (walking or running), the speed during the recording, the record duration in seconds and the user comment about the record.                  The file name on disk is shown in the very top right corner. Click on it to reach it’s location on disk.</p>

<b>D</b>	<p><b><i>Patient, operator, system</i></b>                  When a single record is selected in the list, this section shows the patient identity for the record, the operator who performed the record and basic information on the system used.</p>
<b>E</b>	<p><b><i>Import</i></b>                  Click the import button to import gaitway-3D binary data file(s) (*.g3d) to the local database. A dialog window will prompt the operator to select the location of the source file(s).                  The original data files are not moved nor deleted.</p> <p><b><i>Export</i></b>                  Click the export button to export a copy of the data file(s) to a new location in the specified format or to create an analysis table.                  A dialog window will prompt the operator to select the file format:</p> <ul style="list-style-type: none"> <li>- Data file as binary (Gaitway-3D)(*.g3d)</li> <li>- Data file as text (Tab delimited)(*.txt)</li> <li>- Analysis table as text (Tab delimited)(*.txt)</li> </ul> <p>Depending on the format, the data filtering, strides selections, file name(s) options, etc. are available.</p> <p>A second dialog window will prompt the operator to select the destination folder.                  The original data files are not moved nor deleted.</p>
<b>F</b>	<p><b><i>View</i></b>                  Click this button to open the selected record file in the gaitway-3D data viewer screen. See next section for more details. Alternatively, you can select a file and press the ENTER key or double-click the record in the list.</p>
<b>G</b>	<p><b><i>Report</i></b>                  Once a pdf report has been created from the data viewer interface (see section 5.9.29) the pdf file can be opened directly from the browser interface. The pdf 'Report' button is displayed only when a single file is selected and the pdf file exists.</p>

To permanently delete record(s) from the database, select the record(s) in the list and press the 'Delete' key on keyboard. A prompt will require confirmation to delete the file(s).

### 5.9.21. Data viewer

All recordings listed in the Gaitway-3D records screen can be opened for analysis. Once a file has been selected (see section 5.9.20), the data viewer screen will display the data file content with different views as explained in following sections.

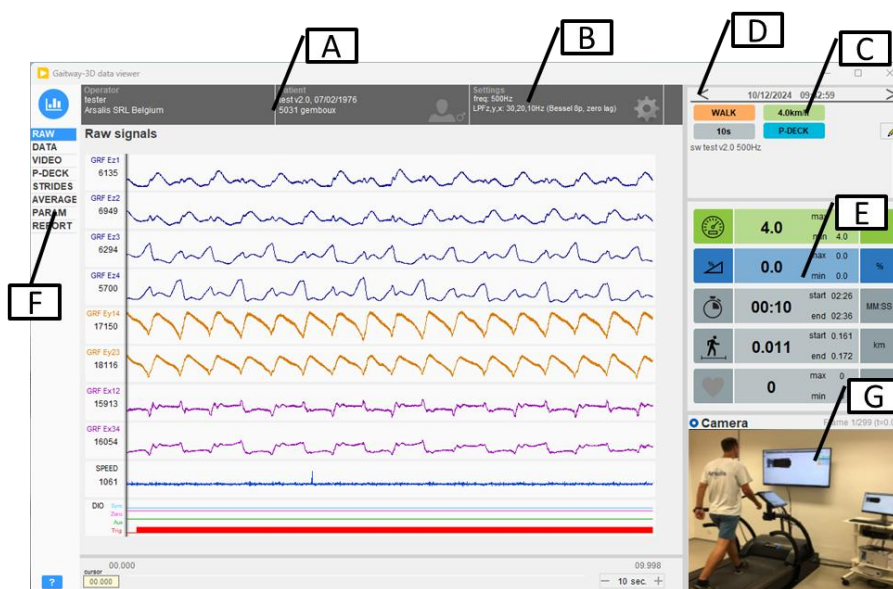



Figure 41: gaitway-3D software data viewer.

<p><b>A</b></p>	<p><b>Patient and operator</b></p> <p>The operator and patient for the displayed record are shown on the top left of the data viewer screen. Click on each box to open the detailed information about the operator or patient identity. Those fields can be edited only if edition is activated by clicking the  'edit' button:</p>
<p><b>B</b></p>	<p><b>Data viewer settings</b></p> <p>The zone <b>B</b> shows information about the settings for the record displayed. Click this zone to open the data viewer settings screen (see <b>Error! Reference source not found.</b>). This screen allows:</p> <ul style="list-style-type: none"> <li>To visualize the record settings, including the ground reaction forces (GRF) and the reference frame. These settings cannot be edited.</li> <li>To change the data display settings:                     <p><u>GRF filtering</u>: The ground reaction forces, center of pressure and moments are filtered using a 4th order Bessel or Butterworth filter applied in both directions, equivalent to a 8th order with zero lag.</p> <p><u>GRF filter cutoff</u>: The cutoff frequencies, in Hertz, for the filtering of the force data. Range from 5Hz to half of the sample rate. The ground reaction forces are filtered according to the cutoff specified for each direction Z, Y and X. The center of pressure components, COPx and COPy are filtered according to the cutoff frequency specified for the Z direction. The free moment, Tz, is filtered according to the lowest cutoff frequency specified for the Y and X directions. The belt speed signal is low-pass filtered using a Bessel filter with a 15Hz</p> </li> </ul>

cutoff.

**FC threshold:** in running, the foot-contact is detected automatically using a vertical force threshold computed for the entire recording. This setting displays what force threshold is used for the current record. In walking, this parameter is Non-Applicable.

**GRF normalization:** Forces can be normalized as a percentage of the subject's body weight (%BW).

**Cycle normalization:** The time scale and the time parameters can be normalized as a percentage of the stride or contact duration.

**Steps display:** The left and right steps for each walking/running stride of the record can be displayed either side by side or superimposed. In the latter case, Fx and Tz of the right side are inversed for best visual comparison.

**Default Strides selection:** defines the default selection within the record's strides list when clicking the "Default" button (see section 5.9.26).

- To view the gaitway-3D amplifier information report: click on the 'GRF' box;
- To view the gaitway-3D treadmill information report: click on the 'Treadmill' box.

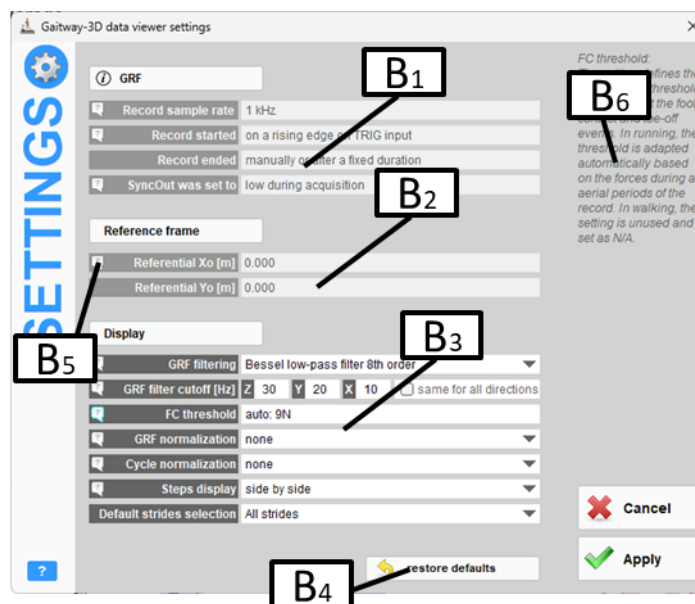



Figure 42: gaitway-3D software data view control screen.

B1	Record settings at acquisition time. Those settings cannot be changed.
B2	
B3	Data display settings. Those settings can be changed for analysis and influence the data processing or display. See details above.
B4	Click this button to reset the Display settings to default values.
B5	Move mouse on the question marks to display help in B6.

<b>C</b>	<p><b>Record description</b></p> <p>This zone shows the date of creation, the tags for the gait type (walking or running), the speed during the recording, the record duration in seconds and the user comment about the record.</p> <p>The comment can be updated by clicking its 'edit' button </p> <p>If a change is made, the operator will be asked to save or discard the change.</p>
<b>D</b>	<p><b>Next/previous record</b></p> <p>The right and left arrows allow to quickly load the next or previous record as listed in the record browser. Use the PageUp and PageDown keyboard shortcuts to load the next or previous record.</p>
<b>E</b>	<p><b>Exercise summary</b></p> <p>This zone shows the summary of the treadmill data measured during the record. The displayed fields are the treadmill speed (average, minimum and maximum), the treadmill elevation (always null) the exercise time (duration, start time and end time), the distance (distance, start and end) and the heart rate (average, minimum and maximum).</p>
<b>F</b>	<p><b>Screen selection</b></p> <p>Different screens are available to display the ground reaction force signals and computed parameters:</p> <ul style="list-style-type: none"> <li>▪ RAW: displays the raw signals acquired by the system. 8 force channels, treadmill speed sensor and amplifier digital lines.</li> <li>▪ DATA: displays measured and computed data signals as a function of time over the full record duration.</li> <li>▪ VIDEO: displays the video (webcam), one signal in sync (selectable) and drawing tools. Snapshots can also be defined for the analysis report.</li> <li>▪ P-DECK*: displays the pressure distribution under each foot and the global COP computed from the pressure deck data.</li> <li>▪ STRIDES: displays the measured and computed data signals for each selected stride.</li> <li>▪ AVERAGE: displays the average (+/- 2SD) of the selected strides data signals.</li> <li>▪ PARAM: displays the biomechanical parameters for the selected strides and according to the gait (either walking or running).</li> <li>▪ REPORT: interface to produce a report as a pdf file.</li> </ul> <p>Each display screen is described with more details in following sections.</p> <p><i>* Display available only with P-Deck Option enabled.</i></p>
<b>G</b>	<p><b>Video</b></p> <p>Video display if a movie file was recorded with the data.</p>

### 5.9.22. Data viewer screen: RAW signals

The RAW signals screen (Figure 43) shows, from top to bottom, 13 signals acquired by the system during the record duration:

- GRF Ez1: vertical force signal on front left transducer, in bits.
- GRF Ez2: vertical force signal on front right transducer, in bits.
- GRF Ez3: vertical force signal on rear right transducer, in bits.
- GRF Ez4: vertical force signal on rear left transducer, in bits.
- GRF Ey14: fore-aft force signal on left transducers, in bits.
- GRF Ey23: fore-aft force signal on right transducers, in bits.
- GRF Ex12: lateral force signal on front transducers, in bits.
- GRF Ex34: lateral force signal on rear transducers, in bits.
- SPEED: Speed sensor measurement, in ticks.
- Sync: Sync-Out digital line, output.
- Zero: Zero digital line, input.
- Aux: Auxiliary digital line, input, can be used for triggered recordings.
- Trig: Trigger digital line, input, can be used for triggered recordings.

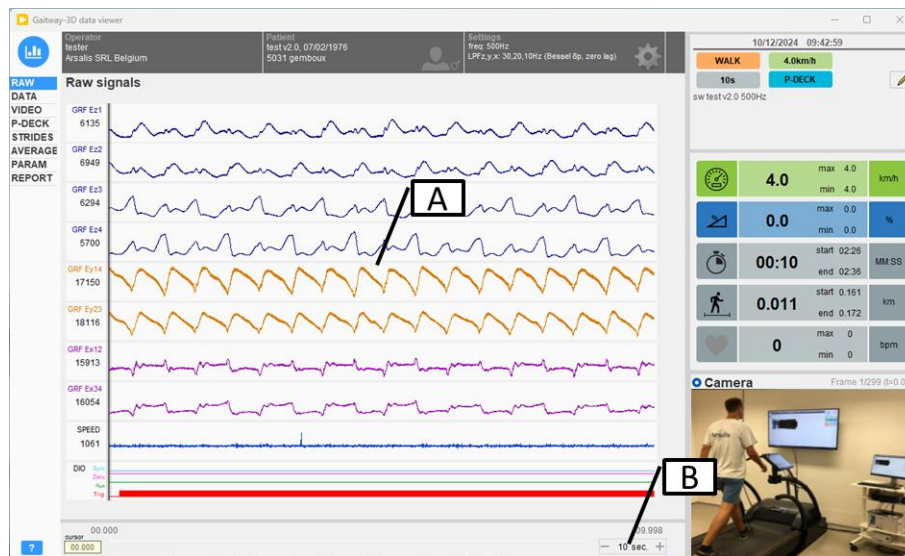

Figure 43: gaitway-3D software data viewer screen: Raw signals.

**A Signals**  
 The 13 signals are displayed in graphs. The range displayed on each chart is auto-scaled at startup and can be adjusted with the mouse scroll-wheel to zoom in/out. The range displayed on each chart appears as tips when placing the mouse cursor on the graph. The digital signals are not scalable. The vertical grey line is a cursor. The cursor can be moved with the left and right arrow keys on keyboard or by mouse dragging. On keyboard, use the shift key for faster cursor displacement. The signals values at cursor are displayed on the left under each signal label. The time position of the cursor is displayed at the bottom left.

**B Time scale**

The graphs can display from 1 to 60 seconds of data. This time scale can be adjusted by placing the mouse pointer over the time scale display and using the mouse scroll-wheel to increase/decrease the time scale in steps of 1 second or by using the +/- buttons.

The graphs time start-end is displayed in this zone.

A horizontal slide allows scrolling the graphs in time.

Right-click on any graph to activate a zoom function: left-click to define start time, hold and move mouse to the right, release left mouse button to define end time.

The display will adapt to the zoomed section with a 1s precision.

**5.9.23. Data viewer screen: DATA signals**

The DATA signals screen (Figure 44) shows 11 graphs:

- Fz, ground reaction vertical force, in Newtons, pounds-force or %BW;
- Fy, ground reaction fore-aft force, in Newtons, pounds-force or %BW;
- Fx, ground reaction lateral force, in Newtons, pounds-force or %BW;
- COPx, center of pressure along the X (lateral) axis and relative to the reference origin, in centimeters or inches;
- COPy, center of pressure along the Y (fore-aft) axis and relative to the reference origin, in centimeters or inches;
- Tz, free moment (in the horizontal plane), in N.m or lbf.ft;
- Treadmill Speed, in km/h or mph;
- TRIG digital line;
- AUX digital line;
- ZERO digital line;
- SYNC digital line.



Figure 44: gaitway-3D software data viewer screen: Data signals.

<b>A</b>	<p><b>Signals</b></p> <p>The data signals are displayed in time graphs. The vertical scale of each graph is auto-scaled and cannot be modified. The data signal unit is shown in the label of the selected signal.</p> <p>Use the vertical slide on the right of the graphs to display the other signals. The vertical grey line is a cursor. The cursor can be moved with the left and right arrow keys on keyboard or by mouse dragging. On keyboard, use the shift key for faster cursor displacement. The signals values at cursor are displayed on the left under each signal label. The time position of the cursor is displayed at the bottom left.</p>
<b>B</b>	<p><b>Time scale</b></p> <p>The graphs can display from 1 to 60 seconds of data. This time scale can be adjusted by placing the mouse pointer over the time scale display and using the mouse scroll-wheel to increase/decrease the time scale in steps of 1 second or by using the +/- buttons.</p> <p>The graphs time start-end is displayed in this zone.</p> <p>A horizontal slide allows scrolling the graphs in time.</p> <p>Right-click on any graph to activate a zoom function: left-click to define start time, hold and move mouse to the right, release left mouse button to define end time. The display will adapt to the zoomed section with a 1s precision.</p>
<b>C</b>	<p><b>Strides identification</b></p> <p>This zone displays the strides cutout. Each box represents a stride; the stride numbering is written above with a "S" prefix and the L/R steps are identified within each box. A stride is always identified as a left step followed by a right step. The strides identification display is scaled according to the time scaling of the graphs and to the window size.</p>
<b>D</b>	<p><b>Video</b></p> <p>The video frame displayed on the right panel synchronizes with the vertical cursor time position. The frame index and time are displayed above the image.</p>

### 5.9.24. Data viewer screen: VIDEO

The video screen (Figure 45) shows the video in a larger view that can be scrolled frame by frame, a synchronized data display and image edition tools.

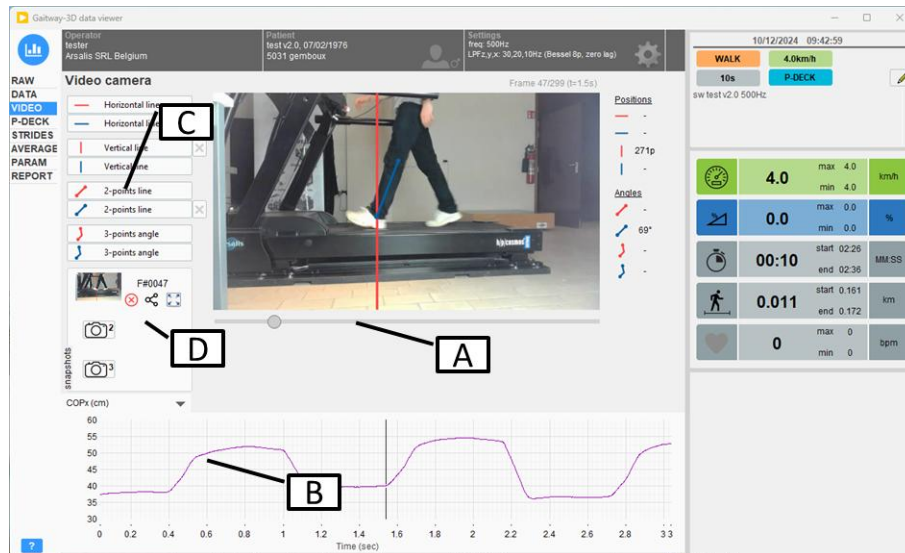

Figure 45: gateway-3D software data viewer screen: Video.

<b>A</b>	<p><b>Video scrolling</b></p> <p>To move one or more video frames forward or backward, use the horizontal slider below the video. The frame index and time are displayed above the image. Alternatively, you can use the keyboard left/right arrows to move one frame forward or backward. Press SHIFT+LEFT or SHIFT+RIGHT to move by 5 frames at a time.</p>
<b>B</b>	<p><b>Data graph</b></p> <p>A data plot with a vertical cursor synchronous with the video frame displayed. The data plotted can be selected above the graph.</p>
<b>C</b>	<p><b>Image edition</b></p> <p>Press one of the buttons on the left of the video to perform an action on the video display. For example, press “Horizontal line” and click on the image. A horizontal line will be drawn on the video, at a fixed position, on all frames. If the button is still active, re-click on the image to move the line. To clear the line, press the cross button that appeared next to the tool. Lines positions (in pixels) or angles (in degrees) are displayed on the right of the image.</p>
<b>D</b>	<p><b>Snapshots</b></p> <p>Three video snapshots can be defined by pressing the buttons. The snapshots include the image, the drawings and the lines positions or angles. Each video snapshot can be deleted, exported as jpg or enlarged using the three small control buttons appearing on the right of each snapshot thumbnail. Each video snapshot will also be added to the pdf report.</p>

### 5.9.25. Data viewer screen: P-DECK

The P-DECK screen (Figure 46) shows the pressure distribution under each foot measured by the Zebris® FDM in a larger view that can be scrolled frame by frame and a synchronized data display.

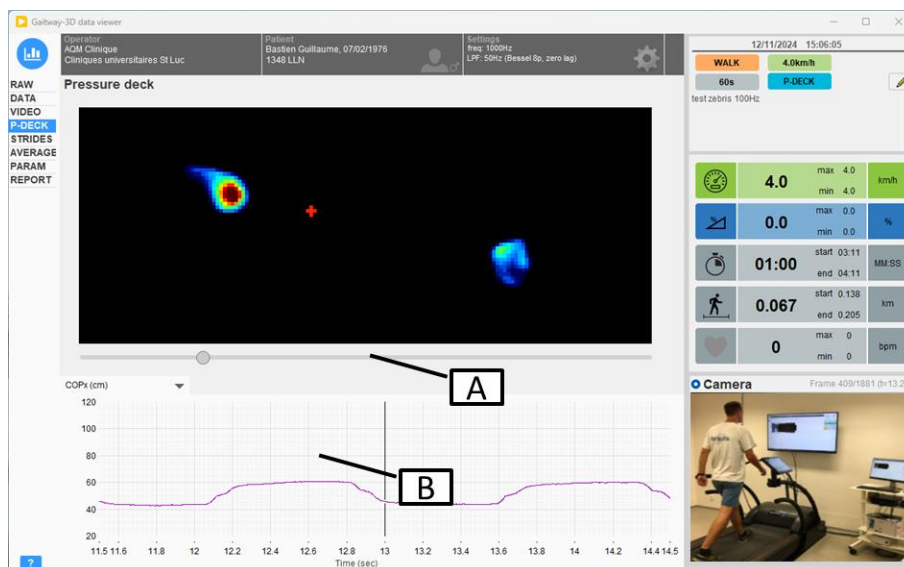

Figure 46: gateway-3D software data viewer screen: Video.

<b>A</b>	<p><b>Pressure scrolling</b></p> <p>To move one or more frame(s) forward or backward, use the horizontal slider below the pressure distribution intensity graph. The frame index and time are displayed above the graph. Alternatively, you can use the keyboard LEFT or RIGHT arrows to move one frame forward or backward. Press SHIFT+LEFT or SHIFT+RIGHT to move by 5 frames at a time.</p>
<b>B</b>	<p><b>Data graph</b></p> <p>A data plot with a vertical cursor synchronous with the pressure frames displayed. The data plotted can be selected above the graph.</p>

### 5.9.26. Data viewer screen: STRIDES signals

The strides signals screen (Figure 47 & Figure 48) shows 8 graphs for the left foot in blue, the right foot in red, and the sum of both feet in grey (if applicable):

- Fz, ground reaction vertical force, in Newtons, pounds-force or %BW;
- Fy, ground reaction fore-aft force, in Newtons, pounds-force or %BW;
- Fx, ground reaction lateral force, in Newtons, pounds-force or %BW;
- 3D-Power, in Watts or W/kg
- COPx vs COPy, center of pressure along the X (lateral) axis as a function of the center of pressure along the Y axis (fore-aft), in centimeters or inches;
- COM, L-side view (COMz vs COMy), body center of mass displacement in the sagittal plane, in centimeters or inches;

- COM, rear view (COMz vs COMx), body center of mass displacement in the frontal plane, in centimeters or inches;
- COM, top view (COMy vs COMx), body center of mass displacement in the horizontal plane, in centimeters or inches;
- Tz, free moment (in the horizontal plane), in N.m or lbf.ft;

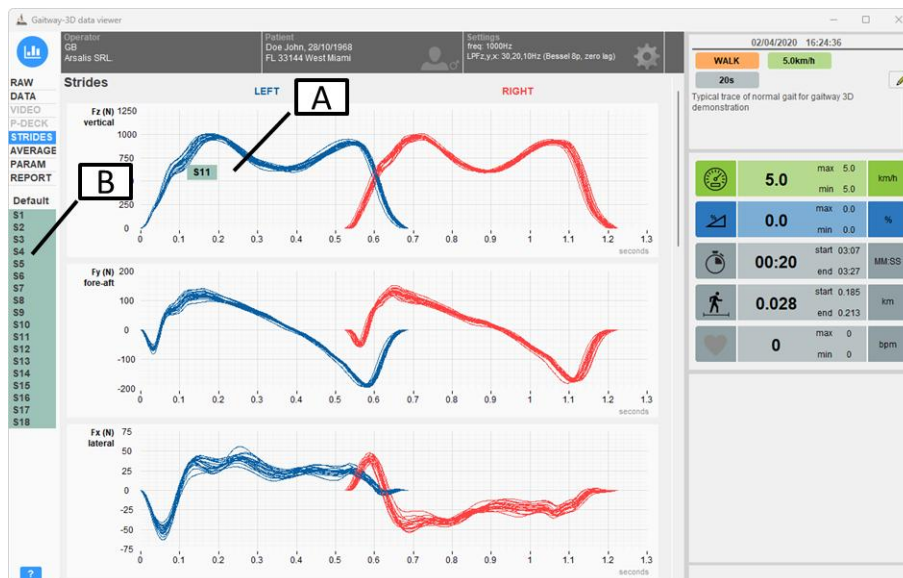

Figure 47: gateway-3D software data viewer screen: Strides signals (1).

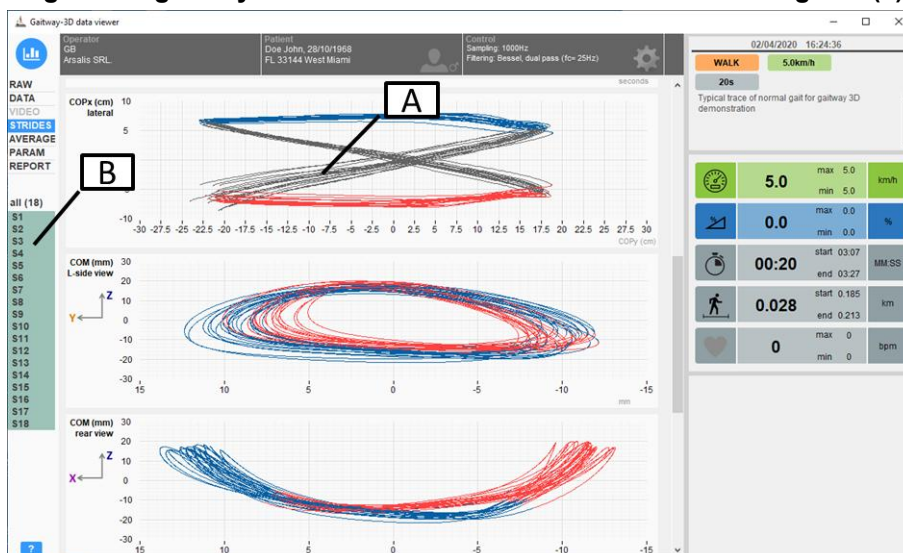

Figure 48: gateway-3D software data viewer screen: Strides signals (2).

**A Signals**  
 The data are sliced in walking or running strides automatically. The signals are then shown for the left steps in blue, the right steps in red and for the sum of both feet in grey.  
 The scales of each graph are auto-scaled and cannot be modified. The data signal unit is shown in the label of the selected signal.  
 Use the vertical slide on the right of the graphs to display the other signals.

	<p>For Fz, Fy, Fx, 3D-Power and Tz plots: The left and right steps can be displayed side by side or superimposed depending on the step display setting (see section 5.9.21 <a href="#">B</a>).</p> <p>Move the cursor over one of the signals in any graph to find-out what strides it represents.</p>
<b>B</b>	<p><b>Stride selector.</b> The left pane displays all identified and selected strides. The graphs are updated based on the strides selection. Click “DEFAULT” to change the selection to the default selection as defined in the Data Viewer Settings section 5.9.21 <a href="#">B</a> or use a custom selection using shift key (for continuous selection) or Ctrl key (for non-continuous selection).</p>

### 5.9.27. Data viewer screen: AVERAGE signals

The average stride signals screen (Figure 49 & Figure 50) shows 7 average graphs for the left foot in blue, the right foot in red, and the sum of both feet in grey:

- Fz, ground reaction vertical force, in Newtons, pounds-force or %BW;
- Fy, ground reaction fore-aft force, in Newtons, pounds-force or %BW;
- Fx, ground reaction lateral force, in Newtons, pounds-force or %BW;
- 3D-Power, in Watts or W/kg
- COPx vs COPy, center of pressure along the X (lateral) axis as a function of the center of pressure along the Y axis (fore-aft), in centimeters or inches;
- COM, L-side view (COMz vs COMy), body center of mass displacement in the sagittal plane, in centimeters or inches;
- COM, rear view (COMz vs COMx), body center of mass displacement in the frontal plane, in centimeters or inches;
- COM, top view (COMy vs COMx), body center of mass displacement in the transverse plane, in centimeters or inches;
- Tz, free moment (in the horizontal plane), in N.m or lbf.ft;

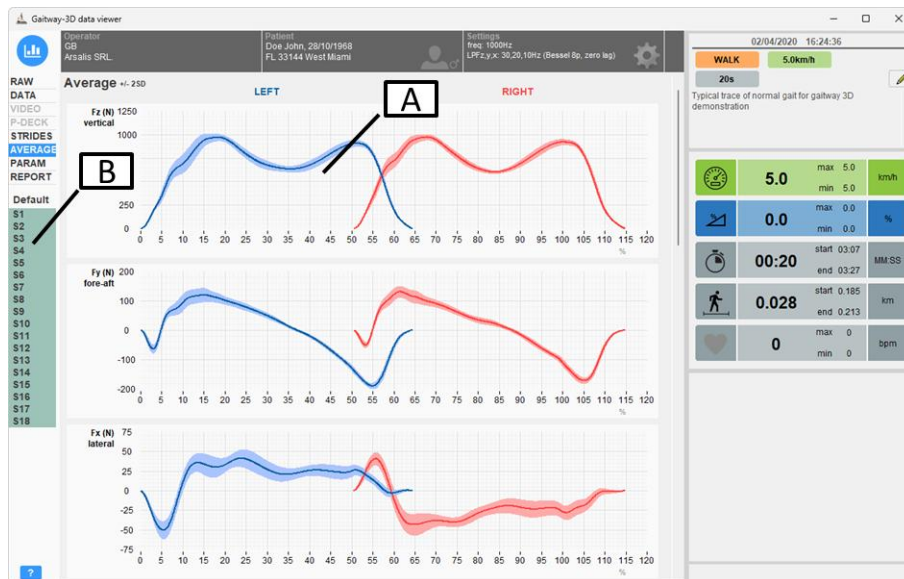

Figure 49: gateway-3D software data viewer screen: Average stride signals (1).

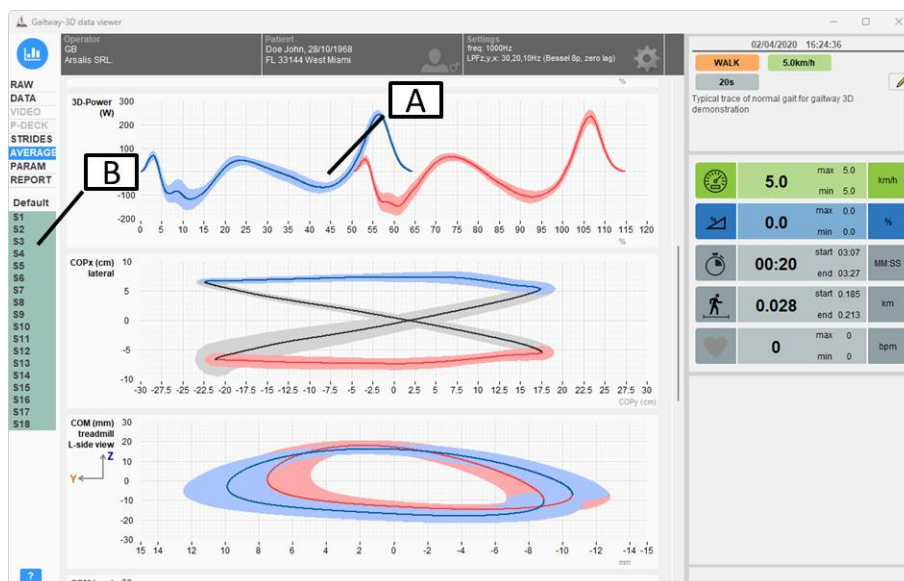



Figure 50: gateway-3D software data viewer screen: Average stride signals (2).

**A Signals**

The data are sliced in walking or running strides automatically. The strides signals are then averaged and shown for the left steps in blue, the right steps in red and for the sum of both feet in grey. The clear blue, clear red and clear grey areas illustrate the 95% confidence interval ( $\pm 2$  standard deviations). The scales of each graph are auto-scaled and cannot be modified. The data signal unit is shown in the label of the selected signal. Use the vertical slide on the right of the graphs to display the other signals. For Fz, Fy, Fx, 3D-Power and Tz plots: The abscissa is expressed in percentage of the stride. The left and right averages can be displayed side by side or superimposed depending on the step display setting (see section 5.9.21 **B**).

**B** ***Stride selector.***

The left pane displays all identified and selected strides. The graphs are updated based on the strides selection.

Click "DEFAULT" to change the selection to the default selection as defined in the Data Viewer Settings section 5.9.21 

or use a custom selection using shift key (for continuous selection) or Ctrl key (for non-continuous selection).

### 5.9.28. Data viewer screen: Parameters

The PARAM screen (Figure 51) reports statistics on the biomechanical parameters measured during walking or running. The list of parameters depends on the type of gait detected and are listed below:

Walking	Running
<ul style="list-style-type: none"> <li>▪ Vertical Impulse (N.s, lbf.s, %BW.s)</li> <li>▪ Loading Rate (N/ms, lbf/ms, %BW/s)</li> <li>▪ Loading Peak Force (N, lbf, %BW)</li> <li>▪ Time to Loading Peak (ms, %stride, %contact)</li> <li>▪ Mid-Support Force (N, lbf, %BW)</li> <li>▪ Time to Mid-Support (ms, %stride, %contact)</li> <li>▪ Push-Off Peak Force (N, lbf, %BW)</li> <li>▪ Time to Push-Off Peak (ms, %stride, %contact)</li> <li>▪ Push-Off Rate (N/ms, lbf/ms, %BW/s)</li> <li>▪ L/P Peak Ratio</li>   <li>▪ Braking Impulse (N.s, lbf.s, %BW.s)</li> <li>▪ Braking Peak Force (N, lbf, %BW)</li> <li>▪ Time to Braking Peak (ms, %stride, %contact)</li> <li>▪ Time to B-P Transition (ms, %stride, %contact)</li> <li>▪ Propulsive Impulse (N.s, lbf.s, %BW.s)</li> <li>▪ Propulsive Peak Force (N, lbf, %BW)</li> <li>▪ Time to Propulsive Peak (ms, %stride, %contact)</li>   <li>▪ Lateral Strike Impulse (N.s, lbf.s, %BW.s)</li> <li>▪ Lateral Strike Peak Force (N, lbf, %BW)</li> <li>▪ Lateral Push Impulse (N.s, lbf.s, %BW.s)</li> <li>▪ Lateral Push Peak Force (N, lbf, %BW)</li>   <li>▪ 3D Collision Peak power (W, W/kg)</li> <li>▪ 3D Loading Peak Power (W, W/kg)</li> <li>▪ 3D Push-Off Peak Power (W, W/kg)</li>   <li>▪ Contact Duration (ms, %stride)</li> <li>▪ Step Duration (ms, %stride, %contact)</li> <li>▪ Double Support Duration (ms, %stride, %contact)</li> <li>▪ Single Support Duration (ms, %stride, %contact)</li> <li>▪ Duty Factor</li>   <li>▪ COM Vertical Displ. (mm, in.)</li> <li>▪ COM Fore-Aft Displ. (mm, in.)</li> <li>▪ COM Lateral Displ. (mm, in.)</li> <li>▪ COM Path (mm, in.)</li>   <li>▪ Step Length (cm, in.)</li>   <li>▪ Cadence (steps/min)</li> <li>▪ Walk Ratio (cm/spm, in/spm)</li> <li>▪ Base of Support Width (cm, in.)</li> <li>▪ Stride Duration (ms, %contact)</li> <li>▪ Mech. Work Recovery (%)</li> <li>▪ Mech. Work Total (J/m, J/kg.m)</li> <li>▪ Mech. Work Vertical (J/m, J/kg.m)</li> </ul>	<ul style="list-style-type: none"> <li>▪ Vertical Impulse (N.s, lbf.s, %BW.s)</li> <li>▪ Impact Loading Rate (N/ms, lbf/ms, %BW/s)</li> <li>▪ Active Loading Rate (N/ms, lbf/ms, %BW/s)</li> <li>▪ Impact Peak Force (N, lbf, %BW)</li> <li>▪ Time to Impact Peak (ms, %stride, %contact)</li> <li>▪ Active Peak Force (N, lbf, BW)</li> <li>▪ Time to Active Peak (ms, %stride, %contact)</li> <li>▪ Push Off Rate (N/ms, lbf/ms, %BW/s)</li> <li>▪ Leg Stiffness (N/mm, lbf/in, %BW/m, %BW/in)</li>   <li>▪ Braking Impulse (N.s, lbf.s, %BW.s)</li> <li>▪ Braking Peak Force (N, lbf, %BW)</li> <li>▪ Time to Braking Peak (ms, %stride, %contact)</li> <li>▪ Time to B-P Transition (ms, %stride, %contact)</li> <li>▪ Propulsive Impulse (N.s, lbf.s, %BW.s)</li> <li>▪ Propulsive Peak Force (N, lbf, %BW)</li> <li>▪ Time to Propulsive Peak (ms, %stride, %contact)</li>   <li>▪ Lateral Strike Impulse (N.s, lbf.s, %BW.s)</li> <li>▪ Lateral Strike Peak Force (N, lbf, %BW)</li> <li>▪ Lateral Push Impulse (N.s, lbf.s, %BW.s)</li> <li>▪ Lateral Push Peak Force (N, lbf, %BW)</li>   <li>▪ 3D Impact Peak Power (W, W/kg)</li> <li>▪ 3D Propulsion Peak Power (W, W/kg)</li>   <li>▪ Contact Duration (ms, %stride)</li> <li>▪ Step Duration (ms, %stride, %contact)</li> <li>▪ Aerial Duration (ms, %stride, %contact)</li> <li>▪ Duty Factor</li>   <li>▪ COM Vertical Displ. (mm, in.)</li> <li>▪ COM Fore-Aft Displ. (mm, in.)</li> <li>▪ COM Lateral Displ. (mm, in.)</li> <li>▪ COM Path (mm, in.)</li>   <li>▪ Step Length (cm, in.)</li>   <li>▪ Cadence (steps/min)</li> <li>▪ Base of Support Width (cm, in.)</li> <li>▪ Stride Duration (ms, %contact)</li> <li>▪ Mech. Work Total (J/m, J/kg.m)</li> <li>▪ Mech. Work Vertical (J/m, J/kg.m)</li> <li>▪ Mech. Work Fore-aft (J/m, J/kg.m)</li> </ul>

- Mech. Work Fore-aft (J/m, J/kg.m)
- Mech. Work Lateral(J/m, J/kg.m)

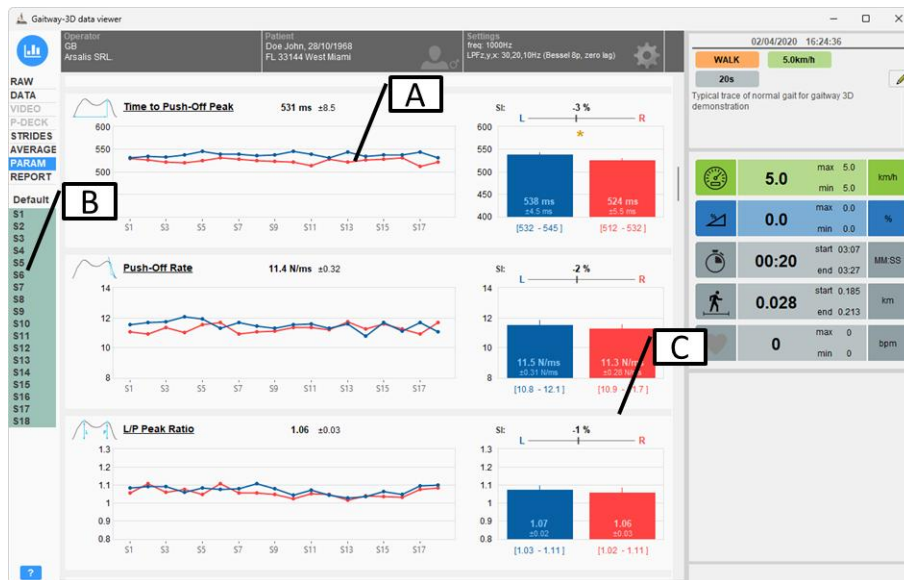

Figure 51: gateway-3D software data viewer screen: Parameters.

- A Parameters plots**  
 The data are sliced in walking or running strides automatically. The gait parameters are then computed for each stride.  
 The gait parameters are shown for the left steps in blue and for the right steps in red.  
 For each parameter, the top value in black displays the average and standard deviation for the selected strides (B). A graph shows the gait parameter value for each stride and for each foot and on the right, a histogram plot shows the average, standard deviation, min-max for each foot individually. Above the histogram, the symmetry index (SI) illustrates the left-right difference. A negative percentage corresponds to higher left foot value for the parameter. A positive SI means that the right step(s) value is greater than the left step(s) value.  
 The SI is computed as:  $SI = [(R-L)/0.5*(R+L)] * 100$   
 Patterson et al., 2010, R 4.  
 The vertical scale of each graph is auto-scaled and cannot be modified. Use the vertical slide on the right side to display the other parameters. The gait parameters depend on the unit system, GRF normalization and cycle normalization settings (see section 5.9.21 B).
- B Stride selector.**  
 The left pane displays all identified and selected strides. The parameters values and graphs are updated based on the strides selection. Click “DEFAULT” to change the selection to the default selection as defined in the Data Viewer Settings section 5.9.21 B or use a custom selection using shift key (for continuous selection) or Ctrl key (for non-continuous selection).

**C T-test**

For each parameter, a Student T-test is performed to compare the left and the right results over the selected strides. When  $p < 0.001$ , a yellow star is shown between the SI value and the histogram plot



- The correct interpretation of ground reaction forces and center of pressure data can only be achieved by experts with knowledge of the biomechanics of locomotion.
- Sudden changes in data and/or high speed changes in data may result from electromagnetic sensitivity of the device or from electrostatic discharge to the device, rather than from physiological signals. Ensure that data are not misinterpreted by repeating and confirming any suspicious recording.

**5.9.29. Data view screen: REPORT**

The report screen (Figure 52) allows customizing and creating a pdf report file. The report file will reflect all settings (filtering, normalization, units, etc.) and the strides selection made for the current data displayed.

At creation, the pdf file will open in the default pdf reader installed on the computer.

The report files are saved in:

...\ProgramData\Arsalis\Gaitway-3D\Gaitway-3D Measurements

With its source data file and the same file name. The pdf file can be re-opened from the data recordings list interface (see section 5.9.20).

The report includes:

- Patient, operator, settings, strides selection and record notes and details
- Analysis comments;
- Optional graph on first page for one or two parameters;
- A summary table of the results for the computed parameters;
- All graphs for averaged strides;
- The video snapshots.

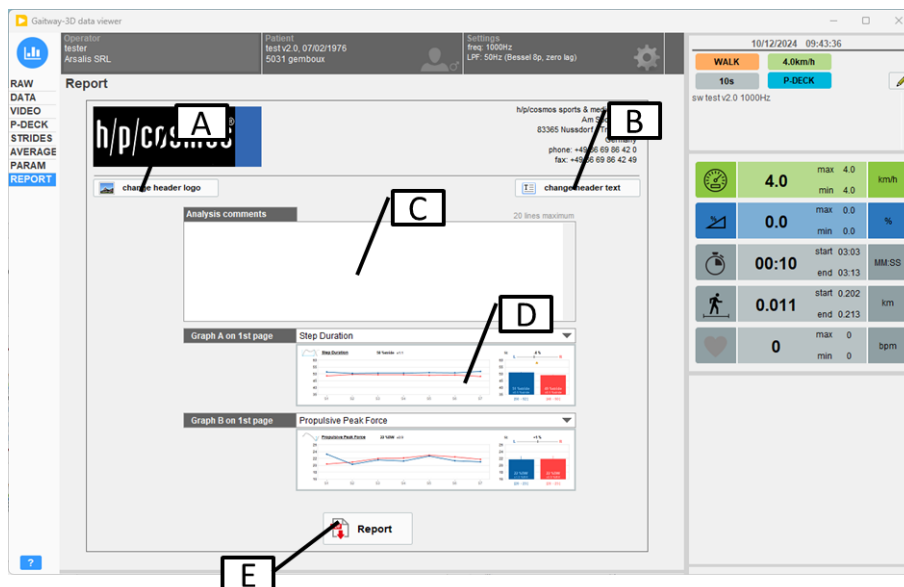

Figure 52: gaitway-3D software data view function screen: Report.

<b>A</b>	<p><b>Header logo</b></p> <p>The header logo printed in the pdf reports can be modified by pressing the “change header logo” button. A file browser window will prompt the operator to locate and select the new logo to use. The logo picture format can be png, bmp or jpg. The logo picture is scaled and resampled to fit in the pdf header and is saved locally by the software. It is the responsibility of the operator to provide a logo picture with the sufficient resolution and size. We recommend a logo picture of 240x76 pixels minimum and 960 x 304 pixels maximum, with 300dpi resolution. A preview of the logo for the pdf header is displayed above the button.</p>
<b>B</b>	<p><b>Header text</b></p> <p>The header text printed in the pdf reports can be modified by pressing the “change header text” button. A pop-up window will prompt the operator to edit the header text. The header text is limited to the width of the text entry box and of maximum 7 lines. Those limitations ensure that the text will fit the pdf header zone. A preview of the text for the pdf header is displayed above the button.</p>
<b>C</b>	<p><b>Analysis comment</b></p> <p>The text zone allows the operator to comment the analysis. Up to 20 lines of comments are allowed. The comment will be displayed in the first page of the pdf report and will be saved with the data file.</p>
<b>D</b>	<p><b>Graphs on first page.</b></p> <p>The operator can select one or two parameter graphs to be displayed in the first page of the pdf report above the analysis comments.</p>
<b>E</b>	<p><b>Report button.</b></p> <p>Press this button to generate the pdf report. The file will open in the default pdf reader and can be saved and renamed from the pdf reader. In any case a copy of each generated report is saved locally in: ...\ProgramData\Arsalis\Gaitway-3D\Gaitway-3D Measurements\...</p>

### 5.9.30. Definitions of biomechanical parameters of walking

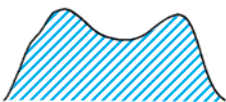
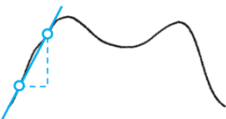
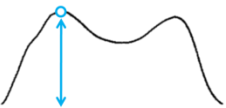
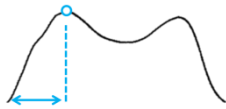
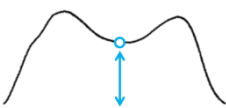
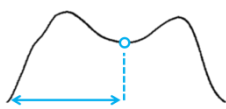

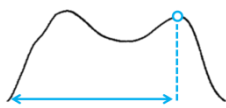

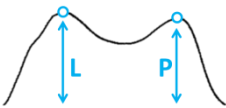
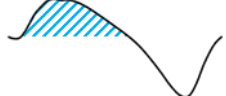
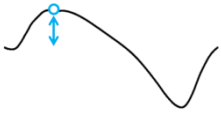
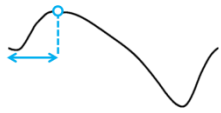
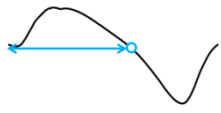
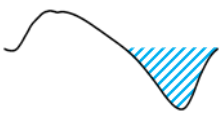

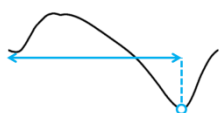

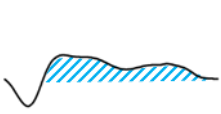



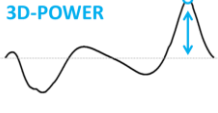
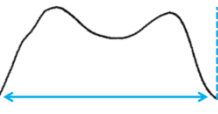
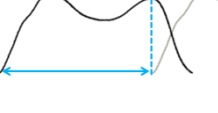



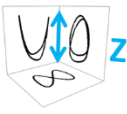

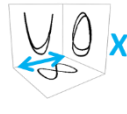





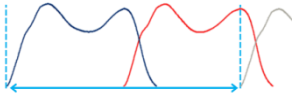





Illustration	Parameter and definition
	<p><u>Vertical Impulse (N.s, lbf.s, %BW.s)</u> The integral, or area under the vertical force time curve during the foot strike.</p>
	<p><u>Loading Rate (N/ms, lbf/ms, %BW/s)</u> The slope of the vertical force time curve during the loading phase, taken from one point at 20% of first peak force and one point at 80% of first peak force.</p>
	<p><u>Loading Peak Force (N, lbf, %BW)</u> The first vertical peak force.</p>
	<p><u>Time to Loading Peak (ms, %stride, %contact)</u> The time from the initial foot contact to the time when the first vertical peak force occurs.</p>
	<p><u>Mid-Support Force (N, lbf, %BW)</u> The minimum vertical force between first and second peak.</p>
	<p><u>Time to Mid-Support (ms, %stride, %contact)</u> The time from the initial foot contact to the time when the mid-support force occurs.</p>
	<p><u>Push-Off Peak Force (N, lbf, %BW)</u> The second vertical peak force.</p>
	<p><u>Time to Push-Off Peak (ms, %stride, %contact)</u> The time from the initial foot contact to the time when the second vertical peak force occurs.</p>
	<p><u>Push-Off Rate (N/ms, lbf/ms, %BW/s)</u> The slope of the vertical force time curve during the unloading phase, taken from one point at 80% of second peak force and one point at 20% of second peak force.</p>
	<p><u>L/P Peak Ratio</u> The ratio of loading vertical peak (L) / push-off vertical peak (P).</p>
	<p><u>Braking Impulse (N.s, lbf.s, %BW.s)</u> The integral, or area under the fore-aft force time curve during the braking phase of the step.</p>

Illustration	Parameter and definition
	<p><u>Braking Peak Force (N, lbf, %BW)</u> The fore-aft braking peak force decelerating the body.</p>
	<p><u>Time to Braking Peak (ms, %stride, %contact)</u> The time from the initial foot contact to the time when the braking peak force occurs.</p>
	<p><u>Time to B-P Transition (ms, %stride, %contact)</u> The time from the initial foot contact to the time when the fore-aft force is null, corresponding to the transition between braking and propulsive phases.</p>
	<p><u>Propulsive Impulse (N.s, lbf.s, %BW.s)</u> The integral, or area under the fore-aft force time curve during the propulsion phase of the step.</p>
	<p><u>Propulsive Peak Force (N, lbf, %BW)</u> The fore-aft propulsive peak force accelerating the body.</p>
	<p><u>Time to Propulsive Peak (ms, %stride, %contact)</u> The time from the initial foot contact to the time when the propulsive peak force occurs.</p>
	<p><u>Lateral Strike Impulse (N.s, lbf.s, %BW.s)</u> The integral, or area under the lateral force time curve during the first phase of the step (negative area for the left steps, positive for the right steps).</p>
	<p><u>Lateral Strike Peak Force (N, lbf, %BW)</u> The lateral peak force under the front foot, during the first phase of the step, pushing the body laterally towards the side of the front foot.</p>
	<p><u>Lateral Push Impulse (N.s, lbf.s, %BW.s)</u> The integral, or area under the lateral force time curve during the second phase of the step (positive area for the left steps, negative for the right steps).</p>
	<p><u>Lateral Push Peak Force (N, lbf, %BW)</u> The lateral peak force pushing the body laterally away from the side of the supporting foot. This peak force is taken as the maximal force occurring after the Lateral Strike Peak.</p>

	<p><b><u>3D Collision Peak Power (W, W/kg)</u></b></p> <p>The 3D-Power is the sum of the force curves multiplied by the speed variations of the center of mass of the body in each direction.</p> <p>The Collision Peak is the minimum value of the 3D-Power curve during the initial double contact or immediately after.</p>
	<p><b><u>3D Loading Peak Power (W, W/kg)</u></b></p> <p>The 3D-Power is the sum of the force curves multiplied by the speed variations of the center of mass of the body in each direction.</p> <p>The Loading Peak is also called “weight acceptance” or “Rebound”. It is the maximum value between the Collision and the Push-off phases.</p>
	<p><b><u>3D Push-Off Peak Power (W, W/kg)</u></b></p> <p>The 3D-Power is the sum of the force curves multiplied by the speed variations of the center of mass of the body in each direction.</p> <p>The Push-Off Peak is the maximum value of the 3D-Power curve during the final double contact phase or immediately before.</p>
	<p><b><u>Contact Duration (ms, %stride)</u></b></p> <p>The time duration from the initial heel contact to the final toe-off or the duration for which force is applied during a foot strike. The initial heel contact and the final toe-off are defined relative to the center of pressure according to R 1.</p>
	<p><b><u>Step Duration (ms, %stride, %contact)</u></b></p> <p>The time duration from the initial heel contact of one foot to the next initial heel contact of the opposite foot. The initial heel contact is defined relative to the center of pressure according to R 1.</p>
	<p><b><u>Double Support Duration (ms, %stride, %contact)</u></b></p> <p>The period of time during a foot strike in which the body is supported by both feet. (The time from the heel strike of the one foot up to the toe-off of the other foot). The initial heel contact and the final toe-off are defined relative to the center of pressure according to R 1.</p>
	<p><b><u>Single Support Duration (ms, %stride, %contact)</u></b></p> <p>The period of time during a foot strike in which the body is supported by only one foot. The initial heel</p>

	contact and the final toe-off are defined relative to the center of pressure according to R 1.
	<u>Duty Factor</u> The ratio of Contact duration / Stride duration.
	<u>COM Vertical Displ. (mm, in.)</u> The vertical displacement (maximum position – minimum position) of the body center of mass during a step, obtained by double integration of the vertical force signal.
	<u>COM Fore-Aft Displ. (mm, in.)</u> The fore-aft displacement (maximum position – minimum position) of the body center of mass during a step, obtained by double integration of the fore-aft force signal.
	<u>COM Lateral Displ. (mm, in.)</u> The lateral displacement (maximum position – minimum position) of the body center of mass during a step, obtained by double integration of the lateral force signal.
	<u>COM Path (mm, in.)</u> The length of the 3D path traveled by the body center of mass during a step.
	<u>Step Length (cm, in.)</u> The fore-aft distance from a foot’s initial contact to the initial contact of the opposite foot.
	<u>Cadence (spm)</u> <i>spm = steps/min</i> The number of foot strikes per minute.
	<u>Walk Ratio (cm/spm, in/spm)</u> The ratio of Step length / Cadence, indicating the overall neuromotor gait control (higher value indicates a higher control). Bogen et al., 2018, R 6.
	<u>Base of Support Width (cm, in.)</u> The average lateral distance between both feet during the contact phases.
	<u>Stride Duration (ms, %contact)</u> The time duration from the initial contact of the left foot to the next initial contact of the left foot.

	<p><u>Mech. Work Recovery (%)</u>                  The percentage of energy recovered during locomotion due to the exchange of energy between potential and kinetic energies.</p> $R\% = 100 * \frac{W_v^+ + W_{kf}^+ + W_{kl}^+ - W_{ext}^+}{W_v^+ + W_{kf}^+ + W_{kl}^+}$
	<p><u>Mech. Work Total (J/m, J/kg.m)</u>                  The total positive mechanical work performed to displace the body center of mass. Also called external work. The work is computed by summing the increments of the total mechanical energy curve during the stride. The work is then normalized distance unit (and per body weight). The total mechanical energy curve is obtained by summing the instantaneous vertical, fore-aft and lateral energy curves.</p>
	<p><u>Mech. Work Vertical (J/m, J/kg.m)</u>                  The vertical positive mechanical work to lift and accelerate upwards the body center of mass. The work is computed by summing the increments of the vertical mechanical energy curve during the stride. The work is then normalized distance unit (and per body weight). The vertical mechanical energy curve is obtained by summing the potential and vertical kinetic instantaneous energy curves.</p>
	<p><u>Mech. Work Fore-aft (J/m, J/kg.m)</u>                  The fore-aft positive mechanical work to accelerate forward the body center of mass. The work is computed by summing the increments of the kinetic fore-aft mechanical energy curve during the stride. The work is then normalized distance unit (and per body weight).</p>
	<p><u>Mech. Work Lateral (J/m, J/kg.m)</u>                  The lateral positive mechanical work to accelerate laterally the body center of mass. The work is computed by summing the increments of the kinetic lateral mechanical energy curve during the stride. The work is then normalized distance unit (and per body weight).</p>

### 5.9.31. Definitions of biomechanical parameters of running

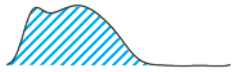

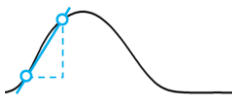



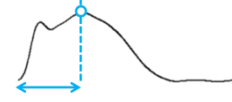



Illustration	Parameter and definition
	<p><u>Vertical Impulse (N.s, lbf.s, %BW.s)</u>                      The integral, or area under the vertical force time curve for each foot strike.</p>
	<p><u>Impact Loading Rate (N/ms, lbf/ms, %BW/s)</u>                      The slope of the vertical force time curve during the loading phase, taken from one point at 20% of impact peak force and one point at 80% of impact peak force.</p>
	<p><u>Active Loading Rate (N/ms, lbf/ms, %BW/s)</u>                      The slope of the vertical force time curve during the loading phase, taken from one point at 20% of active peak force and one point at 80% of active peak force.  <u>The Active Loading Rate is computed only when there is no impact peak detected.</u></p>
	<p><u>Impact Peak Force (N, lbf, %BW)</u>                      The early vertical peak at foot impact.</p>
	<p><u>Time to Impact Peak (ms, %stride, %contact)</u>                      The time from the initial foot contact to the time when the impact peak force occurs.</p>
	<p><u>Active Peak Force (N, lbf, %BW)</u>                      The vertical peak force during the foot contact, after the impact peak.</p>
	<p><u>Time to Active Peak (ms, %stride, %contact)</u>                      The time from the initial foot contact to the time when the active peak force occurs.</p>
	<p><u>Push Off Rate (N/ms, lbf/ms, %BW/s)</u>                      The slope of the vertical force time curve during the unloading phase, taken from one point at 80% of active peak force and one point at 20% of active peak force.</p>
	<p><u>Leg Stiffness (N/mm, lbf/in, %BW/m, %BW/in)</u>                      The stiffness of the leg spring (<math>K_{leg}</math>) computed as the ratio of the maximal vertical force to the compression of the leg.                      McMahon &amp; Cheng, 1990, R 5.</p>
	<p><u>Braking Impulse (N.s, lbf.s, %BW.s)</u>                      The integral, or area under the fore-aft force time curve during the braking phase of the step.</p>



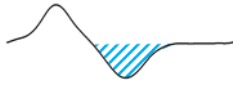
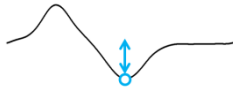
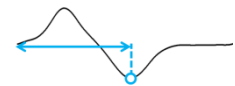

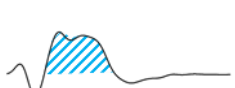

Illustration	Parameter and definition
	<p><u>Braking Peak Force (N, lbf, %BW)</u> The fore-aft braking peak force decelerating the body.</p>
	<p><u>Time to Braking Peak (ms, %stride, %contact)</u> The time from the initial foot contact to the time when the braking peak force occurs.</p>
	<p><u>Time to B-P Transition (ms, %stride, %contact)</u> The time from the initial foot contact to the time when the fore-aft force is null, corresponding to the transition between braking and propulsive phases.</p>
	<p><u>Propulsive Impulse (N.s, lbf.s, %BW.s)</u> The integral, or area under the fore-aft force time curve during the propulsion phase of the step.</p>
	<p><u>Propulsive Peak Force (N, lbf, %BW)</u> The fore-aft propulsive peak force accelerating the body.</p>
	<p><u>Time to Propulsive Peak (ms, %stride, %contact)</u> The time from the initial foot contact to the time when the propulsive peak force occurs.</p>
	<p><u>Lateral Strike Impulse (N.s, lbf.s, %BW.s)</u> The integral, or area under the lateral force time curve during the first phase of the step (negative area for the left steps, positive for the right steps).</p>
	<p><u>Lateral Strike Peak Force (N, lbf, %BW)</u> The lateral peak force under the front foot, during the first phase of the step, pushing the body laterally towards the side of the front foot.</p>
	<p><u>Lateral Push Impulse (N.s, lbf.s, %BW.s)</u> The integral, or area under the lateral force time curve during the second phase of the step (positive area for the left steps, negative for the right steps).</p>
	<p><u>Lateral Push Peak Force (N, lbf, %BW)</u> The lateral peak force pushing the body laterally away from the side of the supporting foot. This peak force is taken as the maximal force occurring after the Lateral Strike Peak.</p>

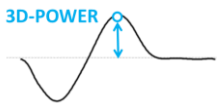
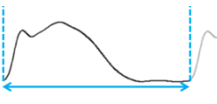
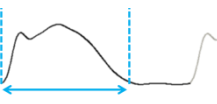
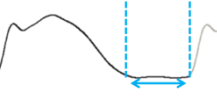

Illustration	Parameter and definition
	<p><u>3D Impact Peak Power (W, W/kg)</u></p> <p>The 3D-Power is the sum of the force curves multiplied by the speed variations of the center of mass of the body in each direction.</p> <p>The Impact Peak is the minimum value of the 3D-Power curve in the first half of the footstrike.</p>
	<p><u>3D Propulsion Peak Power (W, W/kg)</u></p> <p>The 3D-Power is the sum of the force curves multiplied by the speed variations of the center of mass of the body in each direction.</p> <p>The Propulsion Peak is the maximum value of the 3D-Power curve after the Impact.</p>
	<p><u>Step Duration (ms, %stride, %contact)</u></p> <p>The time duration from the initial foot contact to the next initial foot contact of the opposite foot. The initial foot contact is defined for each step as the instant where the low-pass filtered (zero-lag, 8<sup>th</sup> order, 30Hz cutoff) vertical force exceeds the average + 2 standard deviations of its value between the 30<sup>th</sup> and the 80<sup>th</sup> percentile of the previous aerial phase.</p>
	<p><u>Contact Duration (ms, %stride)</u></p> <p>The time duration from the initial foot contact to the final toe-off or the duration for which force is applied during a step. The final toe-off is defined for each step as the instant of the first sample where the low-pass filtered (zero-lag, 8<sup>th</sup> order, 30Hz cutoff) vertical force is below its average + 2 standard deviations of the time between the 30<sup>th</sup> and the 80<sup>th</sup> percentile of the previous aerial phase. See also definition of the initial foot contact above.</p>
	<p><u>Aerial Duration (ms, %stride, %contact)</u></p> <p>The time during which no force is applied during a step. See also definitions of the initial foot contact and final toe-off above.</p>
	<p><u>Duty Factor</u></p> <p>The ratio of Contact duration / Stride duration.</p>

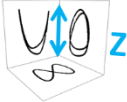
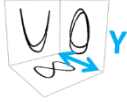
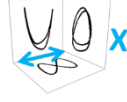
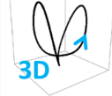
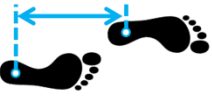

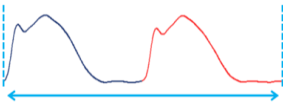



Illustration	Parameter and definition
	<p><u>COM Vertical Displ. (mm, in.)</u>                      The vertical displacement (maximum position – minimum position) of the body center of mass during a step, obtained by double integration of the vertical force signal.</p>
	<p><u>COM Fore-Aft Displ. (mm, in.)</u>                      The fore-aft displacement (maximum position – minimum position) of the body center of mass during a step, obtained by double integration of the fore-aft force signal.</p>
	<p><u>COM Lateral Displ. (mm, in.)</u>                      The lateral displacement (maximum position – minimum position) of the body center of mass during a step, obtained by double integration of the lateral force signal.</p>
	<p><u>COM Path (mm, in.)</u>                      The length of the 3D path traveled by the body center of mass during a step.</p>
	<p><u>Step Length (cm, in.)</u>                      The fore-aft distance from a foot's initial contact to the initial contact of the opposite foot.</p>
	<p><u>Cadence (spm)</u>  <i>spm = steps/min</i>                      The number of foot strikes per minute.</p>
	<p><u>Base of Support Width (cm, in.)</u>                      The average lateral distance between both feet during the contact phases.</p>
	<p><u>Stride Duration (ms, %contact)</u>                      The time duration from the initial contact of the left foot to the next initial contact of the left foot.</p>
	<p><u>Mech. Work Total (J/kg.m)</u>                      The total positive mechanical work performed to displace the body center of mass. Also called external work. The work is computed by summing the increments of the total mechanical energy curve during the stride. The work is then normalized distance unit (and per body weight). The total mechanical energy curve is obtained by summing the instantaneous vertical, fore-aft and lateral energy curves.</p>

Illustration	Parameter and definition
	<p><u>Mech. Work Vertical (J/kg.m)</u></p> <p>The vertical positive mechanical work to lift and accelerate upwards the body center of mass. The work is computed by summing the increments of the vertical mechanical energy curve during the stride. The work is then normalized distance unit (and per body weight). The vertical mechanical energy curve is obtained by summing the potential and vertical kinetic instantaneous energy curves.</p>
	<p><u>Mech. Work Fore-aft (J/kg.m)</u></p> <p>The fore-aft positive mechanical work to accelerate forward the body center of mass. The work is computed by summing the increments of the kinetic fore-aft mechanical energy curve during the stride. The work is then normalized distance unit (and per body weight).</p>

### 5.9.32. Error messages

Error message	Description/troubleshooting
Connection to gaitway-3D failed	Check that the hardware is, plugged, switched on and connected.
User software is not compatible with current firmware	Update the gaitway-3D software.
Firmware update failed: firmware file not found on disk	Install latest version of the software. Request assistance.
Firmware update failed: unknown reason	Install latest version of the software. Request assistance.
Firmware update failed: Update command not acknowledged	Install latest version of the software. Request assistance.
Software could not reconnect to force amplifier after firmware update	Request assistance.
WARNING: FORCE SYSTEM IS SLOWED DOWN AND IS LOSING DATA.	Check that the system requirements are fulfilled. Check that Windows OS is not performing other tasks that require large resources. Sample rate may need to be reduced.
WARNING: DATA TRANSFER INTERRUPTED. RESUMING ACQUISITION. WARNING: DATA TRANSFER INTERRUPTED. DISCONNECTION.	Unable to read data from the amplifier. Check Ethernet cables and check for potential causes for loss of connection or transfer over TCP/IP protocol. Check integrity of the data.
WARNING: Force Amplifier overheating	Switch off the hardware for an hour. Check that nothing covers the force amplifier. Reduce room temperature.
WARNING: FORCE SIGNAL ABOVE RANGE.	Step off the treadmill and update Baselines. If message still appears regularly, request assistance.
WARNING: FORCE SIGNAL BELOW RANGE.	Step off the treadmill and update Baselines. If message still appears regularly, request assistance.
WARNING: View failed.	Unable to read data from the amplifier, Switch off the hardware and restart.
WARNING: Record failed	Switch off the hardware and restart.

<b>Error message</b>	<b>Description/troubleshooting</b>
WARNING: unrecognized end of data transmission	Sample rate must be reduced. Check that the system requirements are fulfilled
WARNING: Treadmill FailSafe activated	The communication to the treadmill via the serial port is interrupted. Switch off the hardware and restart.
WARNING: Lost treadmill command	The communication to the treadmill via the serial port is interrupted. Switch off the hardware and restart.
error code 5000 MCU message checksum error.	The communication to the treadmill via the serial port is interrupted. Switch off the hardware and restart.
error code 5001 MCU message Addressing error.	The communication to the treadmill via the serial port is interrupted. Switch off the hardware and restart.
Error code 5002 MCU message unknown content.	The communication to the treadmill via the serial port is interrupted. Switch off the hardware and restart.
Error code 5003 MCU reported an error at reception.	The communication to the treadmill via the serial port is interrupted. Switch off the hardware and restart.
Error code 1 Invalid message end	A software command to the force amplifier was invalid. Switch off the hardware and restart.
Error code 2 Invalid command	A software command to the force amplifier was invalid. Switch off the hardware and restart.
Error code 3 Invalid number of parameters	A software command to the force amplifier was invalid. Switch off the hardware and restart.
Error code 4 Invalid parameter	A software command to the force amplifier was invalid. Switch off the hardware and restart.
Error code 5 Insufficient bytes	A software command to the force amplifier was invalid. Switch off the hardware and restart.
Error code 6 Error reading bytes	A software communication error occurred with the force amplifier. Switch off the hardware and restart.

Error message	Description/troubleshooting
Error code 7 Error writing flash	An error occurred while writing to force amplifier flash memory. Switch off the hardware and restart.
Error code 8 Error reading flash	An error occurred while reading from force amplifier flash memory. Switch off the hardware and restart.
Error code 32 Error reading bytes	A software communication error occurred with the force amplifier while updating the firmware. The firmware update failed. Switch off the hardware and restart.
Error code 33 Insufficient bytes	A software communication error occurred with the force amplifier while updating the firmware. The firmware update failed. Switch off the hardware and restart.
Error code 34 firmware file size exceeded	A software communication error occurred with the force amplifier while updating the firmware. The firmware update failed. Switch off the hardware and restart.
Error code 35 Flash read error	An error occurred while reading from force amplifier flash memory during firmware update. The firmware update failed. Switch off the hardware and restart.
Error code 36 Firmware write error	An error occurred while writing to force amplifier flash memory during firmware update. The firmware update failed. Switch off the hardware and restart.
Error code 37 Fatal error	An error occurred while verifying the firmware in the force amplifier flash memory during firmware update. The firmware update failed. Switch off the hardware and restart.
Error code 38 Corrupted Firmware	An error occurred while verifying the firmware in the force amplifier flash memory during firmware update. The firmware update failed. Switch off the hardware and restart.

Error message	Description/troubleshooting
Error code -1	The Ethernet connection to the force amplifier does not support the selected sample rate. Select a smaller sample rate and retry data acquisition.
Error code -2	An external device is unexpectedly sending a Zero command via the "Zero in" digital input to the force amplifier during startup. Check that the convention of the external device is according to the specification of section 2.2.2.6. Disconnect any external device from the "Zero in" digital input, switch off the hardware and restart.
Error code -3	An unexpected interrupt occurred in the force amplifier. Switch off the hardware and restart.

## 6. Service

This section includes the service operations to be executed by the customer. All other service operations are to be performed by the manufacturer and are described in the gaitway-3D Service manual.

	<ul style="list-style-type: none"> <li>▪ Installation, commissioning and transport of the device (also opening the device) are to be performed only by trained and authorized technicians who have been certified by Arsalis.</li> <li>▪ In case of a detected and/or assumed malfunction and/or defects and/or unreadable safety labels, the device is to be disengaged immediately. Mark the device and ensure that it cannot be operated. Inform the supplier and authorized service personnel in writing immediately.</li> <li>▪ Disregarding warnings, notifications of intended and forbidden use, precautions as well as unauthorized or lack of maintenance and/or regular safety checks may lead to injuries or death and/or can damage the device. Furthermore it will result in loss of any liability and warranty.</li> <li>▪ All service operations are performed with the mains plug disconnected.</li> </ul>
---	---

	<p>More information on the service of the gaitway-3D treadmill is available in the instructions for use of the h/p/cosmos treadmill ergometer. Please refer to the manual available at the address below:  <a href="https://www.hpcosmos.com/en/contact-support/media-downloads/manuals">https://www.hpcosmos.com/en/contact-support/media-downloads/manuals</a></p>
---	--

## 6.1. Safety notes, warnings and precautions

### 6.1.1. Room conditions and environmental requirements

- Due to the mass of the treadmill, the measurements are sensitive to the vibrations of the floor. Avoid installing the device in a room where the floor is subject to vibrations (e.g. other person are running in the room, displacement of heavy mass, use of other vibrating equipment, subway passage nearby building).
- Operate the device at a temperature of +10 °C to +40 °C with relative humidity of 30 % to 70 % non-condensing, air pressure of 700 to 1060 hPa (maximum 3000m altitude).

	<p>More information on room conditions for the gaitway-3D treadmill is available in the instructions for use of the h/p/cosmos treadmill ergometer. Please refer to the manual available at the address below: <a href="https://www.hpcosmos.com/en/contact-support/media-downloads/manuals">https://www.hpcosmos.com/en/contact-support/media-downloads/manuals</a></p>
---	--

### 6.1.2. Transport and installation

- The device must be installed by trained and qualified technicians certified by Arsalis. The installation instructions are part of the Service manual.
- After the installation, the device must remain bolted to the floor for safe and optimal operation.
- Any transport of the device requires supervision by trained and qualified technicians certified by Arsalis.
- The manufacturer does not assume liability for any damage, complaints or missing parts which are not reported immediately upon delivery on the packing list/delivery note.
- Failure to comply with the conditions listed in this operation and service manual and listed in the operation and service manuals of other respective devices which may be used in connection with this device, failure of performing recommended maintenance and safety inspection intervals, unauthorized maintenance or amendments of the design and/or performance and/or specifications and/or labelling of the devices shall absolve Arsalis from any responsibility for the safety, reliability and performance of this equipment.
- Always ground (earth) the device to prevent electric shock. If the power supply outlet is not grounded, it will be necessary to install a ground by qualified engineers.
- It should be ensured that all cables (power connection, Ethernet, interface, potential equalization, etc.) and accessories are installed properly and safely and that nobody can stumble or fall over the cables and/or accessories.
- All parts should be kept away from children and animals.
- Only connect accessories, software and host equipment if it is confirmed as compatible by all manufacturers.

- It is not allowed to connect sports devices to medical devices such as ECG-systems.
- Connecting a running machine to a medical device results in a medical system. Only trained staff is authorized to perform this connection. Always use IEC 60601-1 approved potential isolation components. This medical system is to be connected via a potential balance cable with the provided connector bolt and bearing within the designated room.
- Do not touch any electrical parts (such as power supply plug) with a wet hand. This may cause electric shock.
- Never put containers with liquid on the device as this may cause electric shock or short circuit when the liquid is spilled.

	<p>More information on transport and installation for the gaitway-3D treadmill is available in the instructions for use of the h/p/cosmos treadmill ergometer. Please refer to the manual available at the address below:</p> <p><a href="https://www.hpcosmos.com/en/contact-support/media-downloads/manuals">https://www.hpcosmos.com/en/contact-support/media-downloads/manuals</a></p>
---	--

### 6.1.3. Storage

- Store the device at a temperature of -25 °C to +40 °C with relative humidity of 0 % to 95 % non-condensing, air pressure of 700 to 1060 hPa (maximum 3000m altitude).

## 6.2. Electrical safety features

The gaitway-3D amplifier is powered by a medical grade AC/DC power supply located inside the treadmill motor compartment with reinforced insulation that is short-circuit proof. It is an extra low voltage safety power supply (12 Vdc).

All external connections to the gaitway-3D amplifier are protected by a main time-delay 800 mA fuse inside the amplifier. This fuse is presented in Figure 53. The fuse is replaceable by the user with a compatible fuse Time-delay, 800 mA, 250 V, 5 mm x 20 mm such as SCHURTER 34.3116 using a screwdriver for unlocking the fuse holder. There is also an additional 100 mA resettable fuse for the supply voltage to the speed sensor.

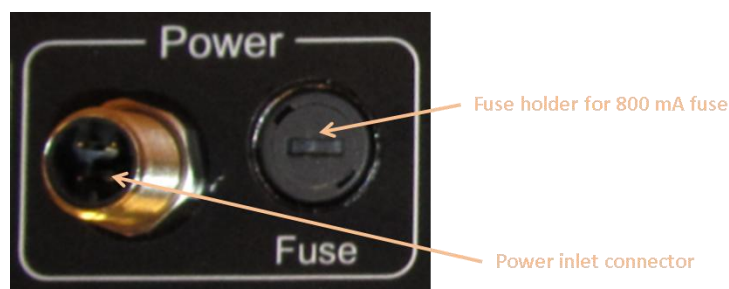

**Figure 53. Fuse protection.**

The digital input and outputs from the BNC connectors to the amplifier are floating and electrically isolated up to 5 kV.

All accessible metallic parts of the gaitway-3D instrumentation are connected to the protective earth.

### 6.3. Connection of external devices via interface

Many optional and host devices (e.g. 3D tracking devices, ECG, spirometry devices, EMG, etc.) which can be connected to the gaitway-3D amplifier or to the treadmill via interface are neither made nor supplied by Arsalis or h/p/cosmos.

	<ul style="list-style-type: none"> <li>▪ Only devices and software which are explicitly declared as compatible by the manufacturer and the manufacturer of the host device (e.g. ECG, spirometry devices, EMG, accessories, software, etc.) are allowed to be connected to the gaitway-3D instrumented treadmill.</li> <li>▪ It is not allowed to connect medical devices (for instance ECG systems) to the gaitway-3D instrumented treadmill.</li> </ul>
---	---

The risk management of Arsalis does NOT cover any parameter which are measured and/or detected by host devices (e.g. 3D tracking devices, ECG, spirometry devices, EMG, etc.) connected to the device.

Accessory equipment connected to the analogue and digital interfaces must be certified according to the respective IEC standards, e.g. IEC 60950-1 for data processing equipment.

	<p>More information on connection of external devices via interface to the gaitway-3D treadmill is available in the instructions for use of the h/p/cosmos treadmill ergometer. Please refer to the manual available at the address below:</p> <p><a href="https://www.hpcosmos.com/en/contact-support/media-downloads/manuals">https://www.hpcosmos.com/en/contact-support/media-downloads/manuals</a></p>
---	---

## 7. Maintenance and safety inspections

	<ul style="list-style-type: none"><li>▪ Maintenance and repair of the device (also opening the device) are to be performed only by trained and authorized technicians who have been certified by Arsalis.</li><li>▪ In case of a detected and/or assumed malfunction and/or defects and/or unreadable safety labels, the device is to be disengaged immediately. Mark the device and ensure that it cannot be operated. Inform the supplier and authorized service personnel in writing immediately.</li><li>▪ Disregarding warnings, notifications of intended and forbidden use, precautions as well as unauthorized or lack of maintenance and/or regular safety checks may lead to injuries or death and/or can damage the device. Furthermore it will result in loss of any liability and warranty.</li><li>▪ All maintenance operations are performed with the mains plug disconnected.</li></ul>
---	---

	<p>More information on maintenance and safety inspection for the gaitway-3D treadmill is available in the instructions for use of the h/p/cosmos treadmill ergometer. Please refer to the manual available at the address below:</p> <p><a href="https://www.hpcosmos.com/en/contact-support/media-downloads/manuals">https://www.hpcosmos.com/en/contact-support/media-downloads/manuals</a></p>
---	---

### 7.1. Measurement accuracy verification

- To ensure the quality of the measurements, it is required to calibrate the instrumentation of the gaitway-3D and to perform a force measurement verification at installation. The calibration and force measurement verification must be performed by trained and authorized technicians who have been certified by Arsalis.
- To ensure the quality of the measurements, it is required to perform a re-calibration of the instrumentation of the gaitway-3D if the device has moved and re-installed. The calibration must be performed by trained and authorized technicians who have been certified by Arsalis.
- To ensure the quality of the measurements, it is recommended to perform a force measurement verification every year after installation as part of the treadmill maintenance. The force measurement verification must be performed by trained and authorized technicians who have been certified by Arsalis.
- To ensure the quality of the measurements, it is recommended to perform a re-calibration of the instrumentation of the gaitway-3D every 5 years after installation. The calibration must be performed by trained and authorized technicians who have been certified by Arsalis.

## 7.2. Preventive maintenance

- The gaitway-3D instrumentation does not require any specific preventive maintenance operations other than the measurement accuracy verification.
- Ensure that all precautions are taken before and during operation.

	<p>More information on preventive maintenance for the gaitway-3D treadmill is available in the instructions for use of the h/p/cosmos treadmill ergometer. Please refer to the manual available at the address below:</p> <p><a href="https://www.hpcosmos.com/en/contact-support/media-downloads/manuals">https://www.hpcosmos.com/en/contact-support/media-downloads/manuals</a></p>
---	--

## 7.3. Immediate maintenance

Immediate maintenance is necessary if:

- the device has been under high mechanical stress (push, damage to amplifier enclosure or other mechanical part);
- fluid has entered the device;
- cable and/or connector plug have been damaged;
- coverings and/or safety warnings have fallen off / broken;
- a defect or malfunction of the device has been detected or is suspected. Abnormal values (e.g. incorrect body weight, abnormal noise on the signals) are measured by the device;
- warnings or error messages from the gaitway-3D software call for immediate maintenance.

	<p>More information on immediate maintenance for the gaitway-3D treadmill is available in the instructions for use of the h/p/cosmos treadmill ergometer. Please refer to the manual available at the address below:</p> <p><a href="https://www.hpcosmos.com/en/contact-support/media-downloads/manuals">https://www.hpcosmos.com/en/contact-support/media-downloads/manuals</a></p>
---	---

## 7.4. Regular inspections / examinations

- The gaitway-3D instrumentation does not require any specific regular inspection / examination.
- Ensure that all precautions are taken before and during operation.

	<p>More information on regular inspection and examinations of the gaitway-3D treadmill is available in the instructions for use of the h/p/cosmos treadmill ergometer. Please refer to the manual available at the address below:</p> <p><a href="https://www.hpcosmos.com/en/contact-support/media-downloads/manuals">https://www.hpcosmos.com/en/contact-support/media-downloads/manuals</a></p>
---	--

## 7.5. Lubrication of the running belt

- After the re-lubrication of the belt as part of treadmill maintenance, and after the oil is distributed evenly, clean any possible oil drops on the load cells cables / foot plates / cable trays / load cells enclosures. Stop the movement of the belt to perform this operation.

	<p>More information on the lubrication of the running belt of the gaitway-3D treadmill is available in the instructions for use of the h/p/cosmos treadmill ergometer. Please refer to the manual available at the address below:  <a href="https://www.hpcosmos.com/en/contact-support/media-downloads/manuals">https://www.hpcosmos.com/en/contact-support/media-downloads/manuals</a></p>
---	--

## 7.6. Control, tightening, adjustment and centering of the running belt

- Incorrect adjustment of the tension or centering of the running belt can alter the quality of the measured data. Ensure that the tension and centering of the running belt is always controlled according to the instruction for the gaitway-3D 150/50 treadmill.

	<p>More information on the control, tightening, adjustment and centering of the running belt of the gaitway-3D treadmill is available in the instructions for use of the h/p/cosmos treadmill ergometer. Please refer to the manual available at the address below:  <a href="https://www.hpcosmos.com/en/contact-support/media-downloads/manuals">https://www.hpcosmos.com/en/contact-support/media-downloads/manuals</a></p>
---	--

## 7.7. Cleansing

- The gaitway-3D instrumentation parts can be cleaned with alcohol impregnated wipes.

	<p>More information on the cleansing of the gaitway-3D treadmill is available in the instructions for use of the h/p/cosmos treadmill ergometer. Please refer to the manual available at the address below:  <a href="https://www.hpcosmos.com/en/contact-support/media-downloads/manuals">https://www.hpcosmos.com/en/contact-support/media-downloads/manuals</a></p>
---	--

### 7.8. Incline handling

- Follow the instructions below if the gateway-3D has the incline option.

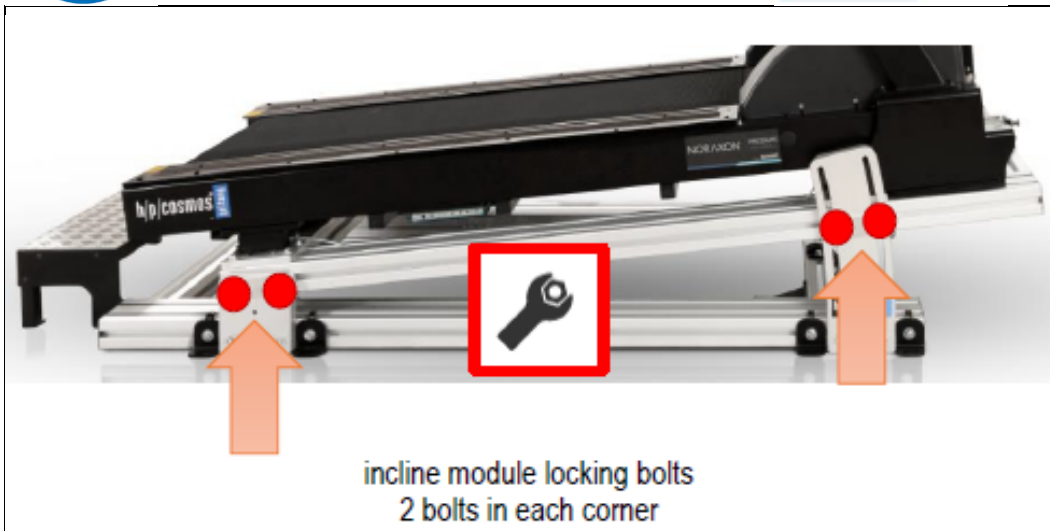

Incline bolts should be tightened when doing measurements, in order to get best data

<b>when in measurement</b>	tighten the locks 
<b>when changing incline</b>	loosen the locks 
<b>when turning ON or OFF the treadmill</b>	loosen the locks 

When turning ON the treadmill at the main switch, the treadmill will always move down to 0% incline, except it is already there. Therefore, the locks must be loose in advance.





Please refer to the manual available at the address below:

<https://www.hpcosmos.com/en/contact-support/media-downloads/manuals>

## 7.9. Portable option handling

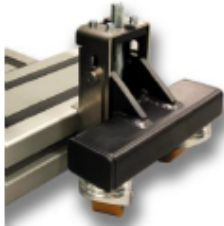
- Follow the instructions below if the gateway-3D has the portable option.



 <p>portable options for gateway 3d allow to move the treadmill within the lab space                      order numbers for this option: cos103971, cos103752vaXX</p>	
<p>The gateway 3d is a sensitive device. Please follow the instructions properly when changing its position within the lab, to avoid calibration impairments and damage.</p>	
<b>incline option</b>	<p style="text-align: center;">in case of a gateway 3d with incline option</p> <ul style="list-style-type: none"> <li>set treadmill to 0% incline</li> <li>tighten all 8 locking bolts from the incline module</li> </ul> 
<b>floor fixation</b>	<ul style="list-style-type: none"> <li>unscrew all fixation bolts from the floor mounting</li> </ul> 
<b>wheels</b>	<ul style="list-style-type: none"> <li>retract the wheels</li> </ul>  <p>important:</p> <ul style="list-style-type: none"> <li>retract all wheels synchronized at the same time (e.g. 4 persons)</li> <li>avoid torsion of the treadmill frame, so do not perform imbalanced lifting heights on the 4 corners</li> <li>only lift the treadmill max. 5 mm</li> </ul>
<b>moving</b>	<ul style="list-style-type: none"> <li>move the treadmill gently and avoid harsh impacts</li> </ul>
<b>new position</b>	<ul style="list-style-type: none"> <li>make sure the treadmill is aligned to the floor anchors</li> <li>lower all wheels at the same time</li> <li>tighten the fixation bolts to the floor anchors</li> </ul>

Please refer to the manual available at the address below:

<https://www.hpcosmos.com/en/contact-support/media-downloads/manuals>

## 8. Troubleshooting

Trouble	Actions
<p>Inaccurate measurement of the ground reaction force or center of pressure</p>	<ul style="list-style-type: none"> <li>▪ Control tightening of the 26 floor anchorage screws of the foot plates (torque: 8Nm).</li> <li>▪ Reduce temperature variations into the room.</li> <li>▪ Wait 15min for warmup before the measurements.</li> <li>▪ Execute a zero command (see section 5.9.5) when no object or person touches the treadmill.</li> <li>▪ Control that no object or person touches the treadmill.</li> <li>▪ Re-calibrate the device</li> </ul>
<p>Inability of the gaitway-3D software to connect to the treadmill or force amplifier</p>	<ul style="list-style-type: none"> <li>▪ Control the serial cable to the treadmill for absence of damage and proper connection.</li> <li>▪ Control the Ethernet connection to the amplifier for absence of damage and proper connection.</li> <li>▪ Verify that the Windows environment has not changed.</li> <li>▪ Verify that the status LED on the force amplifier (red) is blinking at 1 Hz, otherwise cycle the power to the device and try again.</li> <li>▪ Verify that the Ethernet LED on the force amplifier (green) is lit or blinking, otherwise check the Ethernet connection (e.g. replace the Ethernet cable) and try again.</li> </ul>
<p>Inability of the gaitway-3D software to measure data except at low sampling rate.</p>	<ul style="list-style-type: none"> <li>▪ Control the data rate of the Ethernet connection and confirm that it is sufficient.</li> <li>▪ Verify that the network is not used by other applications during the measurements.</li> <li>▪ Verify that the computer resources are not overused by other applications.</li> </ul>
<p>Regular loss of connection of the gaitway-3D software with the treadmill or force amplifier</p>	<ul style="list-style-type: none"> <li>▪ Control the Ethernet and serial cables for absence of damage and proper connection.</li> <li>▪ Verify that the network is not used by other applications during the measurements.</li> <li>▪ Verify that the computer resources are not overused by other applications.</li> </ul>



<b>Trouble</b>	<b>Actions</b>
<p>A sudden change is measured on the signals or a high speed noise is measured on the signals.</p>	<ul style="list-style-type: none"> <li>▪ Check that no source of electromagnetic interference or varying magnetic field (mobile phone, Wi-Fi, ...) is present near the device.</li> </ul>
<p>The force measured by one or more channels is blocked at a fixed value whatever force is applied on the treadmill.</p>	<ul style="list-style-type: none"> <li>▪ The instrumentation might have been affected by an electrostatic discharge.</li> <li>▪ Discharge the patient on an earthed metal piece or the treadmill structure; other persons or objects should not touch the treadmill structure during operations.</li> <li>▪ Interrupt and restart the recording.</li> </ul>

## 9. Technical data

Overview		150/50	170/65	190/65
Instrumentation model		P001	P002	P021
Treadmill model		mercury	stellar	pulsar
Overall dimensions (LxWxH)				
w/o elevation w/o safety arch		230 x 105 x 155 cm	250 x 125 x 155 cm	270 x 125 x 155 cm
w/o elevation w/ safety arch		230 x 105 x 250 cm	250 x 125 x 250 cm	270 x 125 x 250 cm
w/ moving board		230 x 105 x 160 cm	250 x 125 x 160 cm	270 x 125 x 160 cm
w/ moving board & safety arch		230 x 105 x 255 cm	250 x 125 x 255 cm	270 x 125 x 255 cm
w/ elevation w/o safety arch		265 x 110 x 175 cm	290 x 135 x 175 cm	300 x 130 x 175 cm
w/ elevation & safety arch		265 x 110 x 275 cm	290 x 135 x 275 cm	300 x 130 x 275 cm
max elevation w/ safety arch		265 x 110 x 320 cm	290 x 135 x 325 cm	300 x 130 x 330 cm
Mass +safety arch +elevation		273 + 35 + 250 kg	328 + 35 + 292 kg	366 + 35 + 365 kg
Running surface (L x W)		150 x 50 cm	170 x 65 cm	190 x 65 cm
Height of running surface above mounting surface:				
w/o elevation		253 mm	253 mm	253 mm
w/ moving board		293 mm	293 mm	293 mm
w/ elevation at no incline:		454 mm	454 mm	454 mm
Sensor overload	Fx, Fy, Fz	24 kN		
Interfaces		Ethernet interface Analog force and speed output Start and stop digital trigger Serial port for treadmill control		

Performance		150/50	170/65	190/65
Speed		0 ... 18 km/h	0 ... 25 km/h	0 ... 40 km/h
Elevation	optional	0 ... 20 %	0 ... 20 %	0 ... 20 %
Noise	Fx, Fy, Fz	<1.0 Nrms	<1.0 Nrms	<1.0 Nrms
Linearity	Fx, Fy, Fz	<0.2 %	<0.2 %	<0.2 %
Hysteresis	Fx, Fy	<0.8 %	<0.8 %	<0.8 %
	Fz	<0.2 %	<0.2 %	<0.2 %
Cross-talk	Fz → Fx, Fy	<1.0 %	<1.0 %	<1.0 %
Drift	Fx, Fy, Fz	<0.05 N/min	<0.05 N/min	<0.05 N/min
Natural frequency (unloaded, no elevation)	x-axis	≈ 45 Hz	≈ 40 Hz	≈ 35 Hz
	y-axis	≈ 60 Hz	≈ 55 Hz	≈ 45 Hz
	z-axis	≈ 60 Hz	≈ 55 Hz	≈ 45 Hz

Physical	
Operating / storage temperature	10 ... 40°C / -25 ... 40°C
Operating / storage humidity	30 ... 70% (non condensing) / 0 ... 95% (non condensing)
Air pressure	700 ... 1060 hPa (max 3000m altitude)
Ingress protection	IP 00
Audible noise	Noise emission LpA < 70 dB(A) (63db) acc. EN 957-6 Noise emission under load is higher than without load.
Anchorage	24 x HILTI HKD M10x40 or HIT-IC M10x80
Sensors	Strain gauge / Stainless steel tempered

Electrical	150/50	170/65	190/65
Treadmill supply	200 ... 240Vac /16A	200 ... 240Vac /16A	200 ... 240Vac /16A or 3 x 400Vac /16A
Treadmill drive motor	2.2kW	3.3 kW	4.3kW
Amplifier supply	12V DC @ 800 mA		

Amplification				
Amplifier		8 channels: 4x Fz, 2x Fy, 2x Fx		
Analog filter		Bessel 8-pole low pass filter (cut-off frequency: 125 Hz)		
Range adjustable upon request		Min.	Default range	Max.
Measuring range on each sensor	Fx	±0.3 kN	±0.7 kN	±10.9 kN
	Fy	±0.4 kN	±0.8 kN	±12.1 kN
	Fz	0.3 kN	2.5 kN	10.2 kN
Resolution	Fx	22 mN	44 mN	700 mN
	Fy	24 mN	48 mN	775 mN
	Fz	11 mN	91 mN	363 mN
Noise (peak-to-peak)	Fx	±0.5 N	±0.5 N	±1.0 N
	Fy	±0.5 N	±0.5 N	±1.0 N
	Fz	±0.5 N	±0.5 N	±1.0 N
Sensitivity at analog interface	Fx	70 N/V	140 N/V	2300 N/V
	Fy	80 N/V	160 N/V	2500 N/V
	Fz	40 N/V	300 N/V	1200 N/V

Speed sensor	
Range	0.2 ... 40 km/h
Resolution	<0.3% of speed

Ethernet interface	
Connector	RJ-45
Data rate	10 / 100 Mbit/s
Analog-to-digital converter	Built-in, 8 channels, 16-bit resolution, simultaneous sampling
Sampling rate	100 Hz ... 10 kHz

Analog output		
Connector		15-pin Sub-D (HD)
Channels		9 channels: 4x Fz, 2x Fy, 2x Fx, 1x speed
Range	Fx, Fy, Fz	0 ... 10 V
Type	Fx, Fy, Fz	Single-ended ground referenced

Digital input		
Trigger in	BNC	5V digital TTL/CMOS, isolated
Auxiliary in	BNC	5V digital TTL/CMOS, isolated, can be used as trigger
Auto-zero	BNC	5V digital TTL/CMOS, isolated
Sync out	BNC	5V digital TTL/CMOS, isolated

Software	
Data acquisition	gaitway-3D software ©
Functions	Force & center of pressure monitoring, configuration, data recording, gait biomechanical parameters, left/right force under each foot, real-time biofeedback, visualization of recorded data, reporting
Compatibility	Windows 10 / 11
Export file format	Native binary, tab delimited text for data and parameters
Software options	Digital data streaming (Noraxon MR3, Vicon Nexus, Qualisys QTM, Matlab), External left/right force decomposition, Vicon Nexus plugin, Speed perturbation module



More information on the technical data of the gaitway-3D treadmill is available in the instructions for use of the h/p/cosmos treadmill ergometer. Please refer to the manual available at the address below:  
<https://www.hpcosmos.com/en/contact-support/media-downloads/manuals>

## 9.1. Economic life time

The economic life time of the product is considered to be 10 years with normal usage and application, provided the recommended maintenance intervals are kept. Every maintenance and repair work is to be carried out by authorized Arsalis technicians.

	<p>More information on the economic life time of the gaitway-3D treadmill is available in the instructions for use of the h/p/cosmos treadmill ergometer. Please refer to the manual available at the address below:  <a href="https://www.hpcosmos.com/en/contact-support/media-downloads/manuals">https://www.hpcosmos.com/en/contact-support/media-downloads/manuals</a></p>
---	---

## 10. Disposal

The gaitway-3D instrumentation mechanical parts are made of powder coated steel and aluminum parts that should be recycled by bringing them to the official municipal valuable substance depot or to authorized disposal partners of valuable substance disposal.

	<p>The gaitway-3D instrumentation is marked with following sign/symbol on the name plate:                  Symbol for collection, treatment, recycling and disposal of waste electrical and electronic equipment (WEEE) as prescribed in directive 2002/96/EC of January 27, 2003 of the European Parliament and Council: waste electrical and electronic equipment must be collected and recycled to reduce the waste management problems linked to heavy metals and flame retardants.</p>
---	---

	<p>More information on the disposal of the gaitway-3D treadmill is available in the instructions for use of the h/p/cosmos treadmill ergometer. Please refer to the manual available at the address below:  <a href="https://www.hpcosmos.com/en/contact-support/media-downloads/manuals">https://www.hpcosmos.com/en/contact-support/media-downloads/manuals</a></p>
---	---





## 11. Certificates

The gaitway-3D instrumentation is provided with a calibration certificate.

	<p>More information on the certificates of the gaitway-3D treadmill is available in the instructions for use of the h/p/cosmos treadmill ergometer. Please refer to the manual available at the address below:  <a href="https://www.hpcosmos.com/en/contact-support/media-downloads/manuals">https://www.hpcosmos.com/en/contact-support/media-downloads/manuals</a></p>
---	---

## 12. Symbols

All symbols used comply with the respective norms IEC417, IEC878, EN957-1 and Council Directive 2002/96/EC.

	<p>Manufacturer</p>
	<p>Warning / safety precautions Pay attention to accompanying instructions / ISO 7010-W001</p>
	<p>Symbol based on ISO7010:2003-M002. Follow manufacturer's guide, advice, instructions in the manual. Manual contains relevant safety information.</p>
	<p>Symbol for collection, treatment, recycling and disposal of waste electrical and electronic equipment<sup>4</sup> (WEEE) as set out in directive 2002/96/EC of 27 January 2003 of the European Parliament and of the Council on waste electrical and electronic equipment. Necessary to reduce the waste management problems linked to heavy metals and flame retardants</p>
	<p>Manufacturing date</p>

### 13. Contact

For additional orders and technical enquiries please have the serial number of your gaitway-3D instrumentation ready. This number is written on the label on the rear side of the force amplifier.

If you have any further questions about delivery dates, service or maintenance, orders for consumables etc., please contact us.

h/p/cosmos: sports & medical gmbh  
Am Sportplatz 8  
DE 83365 Nussdorf-Traunstein  
Germany  
phone +49 86 69 86 42 0  
fax +49 86 69 86 42 49  
[service@hpcosmos.com](mailto:service@hpcosmos.com)  
[www.hpcosmos.com](http://www.hpcosmos.com)

Arsalis SRL  
c/o UCL - FSM  
Place Pierre de Coubertin, 1 bte L8.10.01  
B-1348 Louvain-la-Neuve  
Belgium  
[arsalis@arsalis.com](mailto:arsalis@arsalis.com)

Contact person:  
Massimo Penta  
Tel. +32 10 47 44 25

## 14. Appendices

### 14.1. Instruction protocol, signatures

By signing this protocol, the authorized Arsalis technician and the customer confirm the receipt and understanding of all warnings, safety information, the performed instruction and commissioning. The customer and user confirm the receipt of the listed devices including all accessories and options according to the delivery note. Disregard of warnings, disregard of intended and forbidden use, safety notes or precautions as well as unauthorized maintenance or lack thereof and/or regular safety checks may lead to injuries or even death and/or can damage the device. This will furthermore result in loss of liability and warranty.

Please fill out the instruction protocol and send a copy to Arsalis via email to [arsalis@arsalis.com](mailto:arsalis@arsalis.com) or via post

**Arsalis SRL**  
**Chemin du moulin Delay 6**  
**B-1473 Glabais**  
**Belgium**

customer's (end-user's) stamp / customer address:

Device, model name	device serial number

Instructor	Arsalis instructor name in clear block letters	date and signature

instructed persons / customer / user / operator	name in clear block letters	function / department	date and signature

## 15. Scientific references

ref. #	Reference
R 1	Meurisse GM et al., <i>Determination of the vertical ground reaction forces acting upon individual limbs during healthy and clinical gait</i> . Gait Posture 43 (2016) 245–250.
R 2	Bastien GJ et al., <i>A robust machine learning enabled decomposition of shear ground reaction forces during the double contact phase of walking</i> . Gait Posture 73 (2019) 221–227.
R 3	Drillis R and R Contini, <i>Body Segments Parameters</i> . Rep. 1163-03, Office of vocational rehabilitation, DHEW, New York, 1966.  In Winter DA, <i>Biomechanics and Motor Control of Human Movement</i> , 4th Edition, 2009.
R 4	Patterson KK et al., <i>Evaluation of gait symmetry after stroke: a comparison of current methods and recommendations for standardization</i> . Gait Posture 31 (2010) 241–246.
R 5	McMahon TA and CG Cheng, <i>The mechanics of running: how does stiffness couple with speed?</i> J Biomech 23 (1990) 65–78.
R 6	Bogen B et al., <i>The walk ratio: Investigation of invariance across walking conditions and gender in community-dwelling older people</i> . Gait Posture 61 (2018) 479–482.